

ROYAL ENFIELD OWNER'S MANUAL



Foreword

We congratulate you on your choice of the legendary Bullet motorcycle and welcome you to the exciting world of motorcycling on a Royal Enfield. This manual will help you to operate your Classic 500cc motorcycle, the right way and guide you to maintain your motorcycle meticulously. We have also provided tips on safe riding and on minor adjustments for the care of your motorcycle. Please avail the four free services at the nearest Authorised Service Point, at the appropriate time to maintain your Bullet motorcycle in top riding condition. Log on to the exciting world of Royal Enfield website: www.royalenfield.com to get to know more about the company, its products and exciting news from time to time. We request you to carefully read the terms and conditions of warranty and other useful information given in this manual before starting to use your Bullet Motorcycle.

Service Headquarters

Royal Enfield, A Unit of Eicher Motors Limited,
Tiruvottiyur High Road, Tiruvottiyur, Chennai - 600 019.
Phone : 044 - 4223 0400, Fax : 044 - 4201 1719
E-mail : customerservice@royalenfield.com
Website : www.royalenfield.com

Notice

2

All information in this manual is based on the latest product information available at the time of publication. Due to continues improvements or other changes, there may be discrepancies between information in this manual and your vehicle. Royal Enfield reserves the right to make production changes at any time without prior notice and without incurring any obligation to make same or similar changes to vehicles previously built or sold.

All images shown are for reference to explain and need not to be exactly the same on the model you own. Technical specification are subject to change without prior notice.

“© Copyright 2014 Royal Enfield (A unit of Eicher Motors Ltd.). All Rights Reserved. No part of this manual shall be copied, distributed or otherwise dealt without the express permission in writing of Royal Enfield.

Applicable for Classic Desert Storm Model

Disclaimer

Care needs to be taken as instructed below in order to ensure a longer life for the paint.

1. Do not polish your motorcycle as it increases gloss.
2. Wash only with plain water.
3. Scratches or marks cannot be removed.

Part No. 591822 / B / Qty. 800 / Apr. '14

No warranty for DESERT STORM Colour

Contents

3

PERSONAL & VEHICLE INFORMATION ...	6	● Left Side View	23
FREE SERVICE RECORD	7	● Top View	24
TECHNICAL SPECIFICATIONS	8	OPERATION OF CONTROLS.....	25
● Engine	8	● Ignition Switch	25
● Ignition System	9	● Steering Lock.....	25
● Transmission	9	● Fuel tank cap	26
● Electricals	10	● Side Box	26
● Chassis	11	● Battery Carrier	27
● Dimensions.....	12	● Utility Box	27
● Weights	12	● Head lamp switch	28
SAFETY DEFINITIONS	13	● Head lamp Day flash	28
SAFE DRIVING TIPS/GUIDELINES.....	14	● Dip Switch	28
SAFE & HAPPY RIDING	18	● Engine Start Switch	29
RULES OF THE ROAD	19	● Engine Stop Switch	29
VEHICLE IDENTIFICATION	21	● Turn Signal Switch	29
● Chassis Number.....	21	● Horn	30
● Engine Number	21	● Manual Bi Starter (choke)	30
KEY PARTS LOCATION	22	PRE OPERATIONAL CHECKS	31
● Right Side View	22	RUNNING IN PERIOD.....	32

Contents

4

ELECTRONIC FUEL INJECTION & MIL.....	33		
● EFI	33	● Brake fluid	49
● The Advantages of EFI	33	● Inspection of tyres and wheels.....	49
● Malfunction Indicator Lamp (MIL).....	33	● Tyre pressure	50
ROLL OVER SENSOR	34	● Front Wheel removal	50
STARTING	35	● Front Wheel assembly.....	51
GEAR SHIFTING	38	● Rear wheel removal	52
PARKING	39	● Rear wheel assembly.....	53
● Center Stand	39	● Adjustments-Clutch	54
● Side Stand	39	● Drive Chain free play	54
TOOLS & FIRST AID KIT	40	● Checking Rear Brake Pedal Height.....	55
RECOMMENDED LUBRICANTS	41	● Rear Brake free play adjustment.....	56
PERIODICAL MAINTENANCE	42	● Chain lock fitment	56
MINOR MAINTENANCE TIPS	46	● Adjustment of gas shockabsorber	57
● Control Cables, Hand lever, Pivots, Center / Side Stand Pivots	46	● Removal of Battery on Vehicle	58
● Oil Level Inspection	46	● Battery Maintenance	58
● Engine oil change	47	● Assembly of Battery on Vehicle	59
● Spark Plug	48	CHANGING ELECTRICAL COMPONENTS	60
		● Head Lamp Bulb Replacement.....	60
		● Assembling the Head Lamp	61

Contents

5

● Tail Lamp bulb Replacement.....	62	● White / Blue smoke	74
● Trafficator bulb Replacement.....	62	● Engine overheating	74
● Fuse	63	● Excessive fuel consumption.....	74
● Blade fuse usage list.....	63	● Brakes Poor.....	75
AIR FILTER PAPER ELEMENT.....	64	● Vehicle wobbles	75
PILLION(REAR)SEAT REMOVAL & REFITTING	65	● Electricals	75
● Pillion (Rear) seat removal.....	65	● Electronic Fuel Injection (EFI)	76
● Pillion (Rear) seat refitting.....	66	WARRANTY	77
WASHING PROCEDURE	67	EMISSION WARRANTY	79
● Precautions	67	ALL INDIA ROAD SIGNS	83
● After washing	67	FREE SERVICE COUPONS	84
STORAGE PRECAUTION.....	68	PAID SERVICE / MAINTENANCE RECORD..	93
● Preparing the motorcycle for re-use.....	69	LOG BOOK	101
LONG TRIP PRECAUTIONS.....	70	NOTES	103
COMPLETE WIRING DIAGRAM.....	71	ANNEXURES	
TROUBLE SHOOTING	72	● Vehicle Installation Form	
● Engine fails to start	72	● Pre-Delivery Inspection Report	
● Engine misfiring	73	● Bike Installation Confirmation By Customer	
● Poor pickup	73	● Form 22	

Free Service Record

It is our endeavour to provide excellent service to your Classic 500 at all times. Towards this we provide 4 free services at specific Intervals.

Please avail these services at the specified time, in any of the Royal Enfield Authorised Dealer / Service Point nearest to you and as a token of satisfactory services, kindly return the free service coupon duly filled in and signed, to the service outlet.

Availing the free services in the specified time is a prerequisite for warranty consideration. The cost of fuel, oil, grease etc. used for all free services are chargeable to the customer.

	1 st Service					2 nd Service					3 rd Service					4 th Service				
Date of Service																				
Kms Covered																				
Servicing ASP / Dealer's Name Address	Dealer / ASP Rubber Stamp					Dealer / ASP Rubber Stamp					Dealer / ASP Rubber Stamp					Dealer / ASP Rubber Stamp				

NOTE : Please ensure that the free service details are recorded in this sheet immediately after the service is carried out.

Technical Specification

ENGINE

Engine	4 Stroke, air cooled, single cylinder, OHV, SI & FI Engine
Capacity	499 cc (Displacement)
Bore	84 mm
Stroke	90 mm
Compression ratio	8.5 : 1
Max. Power @ RPM	27.2 BHP @ 5250 rpm
Max. Torque @ RPM	41.3 Nm @ 4000 rpm
Air Filter Element	Corrugated Paper Element
Engine Oil Capacity	2.75 Litres.
Lubrication	Forced Lubrication, Wet Sump
Engine Oil Grade	Royal Enfield 15W50 API SL Grade Engine Oil (JASO MA)
Cooling system	Natural Air Flow
Fuel Supply	Electronic Fuel Injection Programmed (PGM-EFI)



Technical Specification

IGNITION SYSTEM

Ignition system	Electronic Ignition (ECU / Variable)
Spark plug Electrode gap	0.70 to 0.80 mm
Spark plug	WQR8DP (Bosch Super) M14 & UR6DC (Bosch Super) M10

TRANSMISSION

Clutch	Wet Multiplate (7 Plates)
Primary drive	Duplex Chain
Primary Drive Ratio	2.15 : 1
Gear box	Constant Mesh 5 Speed
Gear shift pattern	1 - N - 2 - 3 - 4 - 5
Gear Ratios	1st-3.06:1 2nd-2.01:1 3rd-1.52:1 4th-1.21:1 5th-1:1
Secondary Drive (F.D. Sprocket)	18 Teeth
Final ratio	2.11 : 1
Drive Chain links	102 links

Technical Specification

ELECTRICALS

Generation	Alternator
System	12V DC
Battery	12V - 14 AH MF
Head lamp	12V, 60/55 W, Halogen
Position lamp	12V, 4W
Brake / Tail lamp	12V, 21/5 W
Turn signal	12V, 10W - 4 nos.
Pilot lamp	12V, 2 W - 2 nos. & 12V, 4 W - 1 no.
Speedometer lamp	12V, 3.4 W - 1 no.
Turn signal / High beam indicator	12V, 2 W - 2 nos.
Neutral Indicator	12V, 2 W - 1 no.
Horn (Dual)	12V, 2.5 Amp (Max.) X2
Starter Motor	12V, 0.9 KW

 WARNING Using bulbs / other electrical gadgets other than specified rating may lead to over loading / erratic behaviour / premature failure of electrical system. Modifications on the bike which are not approved by Royal Enfield may not only disqualify for warranty, but also affects performance of the bike.
--

Technical Specification

CHASSIS

Frame	Tubular Frame
Tyre size	Front: 90 / 90 - 19" - 52 P Rear: 120 / 80 - 18" - 62 P
Tyre pressure	Front- Solo: 1.41 Kg/cm ² (20 PSI) Pillion: 1.55 Kg/cm ² (22 PSI) Rear- Solo: 2.11 Kg/cm ² (30 PSI) Pillion: 2.25 Kg/cm ² (32 PSI)
Fuel tank capacity	13.5 Litres***
Low fuel warning	2.5 Litres (approx)
Dead stock of petrol (unusable fuel)	0.75 Litres (approx)
Suspension	Front: Telescopic (Dia 35mm), Hydraulic Damping Stroke 130mm Rear: Swing arm with gas filled shock absorbers Stroke 80 mm
Front fork oil capacity	195 ml per leg
Front fork oil	1F Endurance (or Royal Enfield) fork oil
Brakes	Front : Hydraulic 280 mm Ventilated Disc Rear : Foot Operated 153mm Single Lead Internal expanding
Brake oil capacity	60 ml
Brake oil grade	DOT 3 or DOT 4

***Fuel tank is not a measuring instrument.
The capacity of tank may vary slightly from specified value.

Technical Specification

DIMENSIONS

Length	2170 mm
Width	800 mm
Height	1070 mm
Wheel base	1370 mm
Saddle height	800 mm
Ground clearance	135 mm

NOTE: BS III This vehicle meets Emission Norms - Bharat (Trem) Stage - III

WEIGHTS

Kerb Weight (with 90% Fuel)	190 Kg
Max pay load	175 Kg

NOTE :

1. Values / Dimensions given above are for your guidelines only.
2. In view of continuous improvements being done on our products, the specifications are subject to change without notice.

Safety Definitions

13

The information given under the titles : Warning, Caution and Note are for your safety and for the care and safety to your motorcycle and others. Please read these carefully and if disregarded may result in injury to yourself or others and damages to the motorcycle.

 **Warning**

Indicates a potentially hazardous situation. Disregarding this message may result in injury to rider or other persons.

CAUTION :

This message if disregarded may result in damage to the vehicle.

NOTE :

Indicates important and useful messages for clear understanding.

Safe Riding Tips / Guidelines

14

- Before operating your new motorcycle, it is your responsibility to carefully read and follow the operating and maintenance instructions detailed in this manual for your own safety, your motorcycle and that of others.
- Know and respect the rules of the road. Be a safe rider for your own safety and for other road users.
- Before starting the motorcycle, check for proper operation of brakes, clutch, gear shifter, handle bar controls, tyre pressures, fuel and oil levels.
- Use only genuine Royal Enfield spare parts and approved accessories. Use of other manufacturer's performance parts may affect the performance of your motorcycle and render the motorcycle void of warranty. See your Royal Enfield dealer for details.
- Whenever refuelling your motorcycle, please exercise utmost caution and carefully observe the following rules :
 - * DO NOT smoke and please ensure that there are no open flames or sparks near the motorcycle, when refuelling OR servicing the fuel system.
 - * Switch OFF mobile phones and other hand held electronic devices.
 - * Open the fuel filler cap slowly.
 - * Refuel in a well ventilated area with the engine turned off.
 - * DO NOT fill the tank to its brim. Please fill fuel only till the bottom of the filler neck insert, so as to leave air space in the fuel tank to allow for fuel expansion.



Warning

Royal Enfield cautions you against the use of certain nonstandard parts such as aftermarket and custom made extended front forks or suspensions, which may adversely affect performance and handling. Removing or altering original parts may adversely affect performance and could result in an accident.

Safe Riding Tips / Guidelines

15

- A new motorcycle must be operated according to the special running-in-procedure. See running-in-procedure mentioned in Page No. 32.
- Operate motorcycle only at moderate speeds and out of traffic until you have become thoroughly familiar with its operation and handling characteristics under all conditions.
- DO NOT exceed the legal speed limit or drive too fast for existing conditions. Always reduce speed when poor driving conditions exist. High speed increases the influence of any other condition affecting stability and increases the possibility of loss of control.

NOTE :

If you are an inexperienced rider we recommend that you obtain formal training on correct motorcycle riding techniques and become thoroughly familiar with the operation of your particular motorcycle. New riders should gain experience under various conditions while driving at moderate speeds.

Pay strict attention to road surfaces and wind conditions. Any two wheeled vehicle may be subject to the following upsetting forces :

- * Wind blasts from passing trucks.
- * Rough uneven road surfaces.
- * Slippery road surfaces.

These forces may affect the handling characteristics of your motorcycle. If this happens, reduce speed and guide the motorcycle with a relaxed grip to a controlled condition. Do not brake abruptly or force the handlebar.

- Operate your motorcycle defensively. Remember, a motorcycle does not afford the same protection as an automobile in an accident. One of the most common accident situations occurs when the driver of the other vehicle fails to see or recognize a motorcycle and turns into the oncoming motorcyclist.

Safe Riding Tips / Guidelines

16

- Wear an approved helmet, clothing, and foot gear suited for riding a motorcycle. Bright OR light colors are best for greater visibility in traffic, specially at night. Avoid loose, flowing garments and scarves.
- When carrying a pillion rider, it is your responsibility to instruct them on proper riding procedures.
- DO NOT allow other individuals, under any circumstances, to operate your motorcycle unless you know they are experienced, licensed riders and are thoroughly familiar with the operating conditions of your motorcycle.

Warning

Regularly inspect shock absorbers and front forks and look for leaks. Replace worn parts. Worn parts can adversely affect stability and handling.

Warning

For your personal welfare, all the listed service and maintenance recommendations should be performed. Lack of regular maintenance at the suggested intervals may affect the safe operation of your motorcycle.

Warning

Avoid any contact with the exhaust system. Wear clothing that will completely cover the legs while riding. The exhaust system gets very hot when the engine is running and remains too hot, even after the engine is turned off. Failure to wear proper or protective clothing could result in serious injury.

Warning

Exhaust gases contains poisonous carbon monoxide and chemicals, known to cause Cancer, Birth Defects or other reproductive defects.

Safe Riding Tips / Guidelines

17

 **Warning**

Motorcycle batteries contain lead and lead components, acids and chemicals known to cause cancer, birth defects or other reproductive harm. Exercise extreme caution while handling a battery. Wash hands thoroughly whenever a battery is handled.

 **Warning**

DO NOT tow a disabled motorcycle. The steering and handling of the disabled motorcycle will be impaired due to the force of the towline. If a disabled motorcycle must be transported, use a truck or a trailer. Towing a motorcycle may cause loss of control of the motorcycle in the front, leading to an accident.

 **Warning**

Consult your Royal Enfield Dealer regarding any questions or problems that occur in the operation of your motorcycle. Failure to do so may aggravate an initial problem, cause costly repairs & jeopardize your personal safety.

 **Warning**

DO NOT pull a trailer behind a motorcycle. Towing a trailer may cause reduced braking efficiency, tyre overloading and unstable handling. Towing a trailer may cause loss of control of the motorcycle in the front, leading to an accident.

Safe & Happy Riding

18

RIDING DRESS

- Please wear a proper riding apparel.
- A pair of riding boots or shoes.
- Soft leather gloves.
- Goggles or spectacles to safe guard eyes.
- A certified helmet. Affix light reflecting strips of stickers at the front and rear.

NOTE :

A light coloured shirt enables greater visibility to other road users specially during nights.

CAUTION :

Loose clothing may get caught on moving parts of your motorcycle.

SITTING POSTURE

Correct sitting posture is a pre-requisite for stable and safe riding

- Sit Straight with your shoulders completely relaxed.
- Keep your elbows close to your body.

- Keep your toes in straight ahead direction.
- Slightly grip the petrol tank with both knees.
- Hold the handle bar grips, close to its inner end.
- Look extensively ahead, including rear view mirrors, without turning the head.

BRAKING

- Apply front and rear brakes gently and simultaneously for maximum braking efficiency.



WARNING

Applying any one of the brakes suddenly may cause the vehicle to skid. The hydraulic disc brake fitted on your motorcycle requires very less effort. High effort or sudden application may lock the wheel. Please use utmost caution while applying the brakes.

- While riding on wet or bad road conditions use brakes cautiously.
- Avoid excessive banking, otherwise footrest may touch the ground and cause instability.

Rules of the Road

19

- Be sure your number plate is installed in the position specified by law and is clearly visible at all times.
- Ride at a safe speed that is consistent with the type of road surface you are on. Pay strict attention to whether the surface is :
 - * Dry
 - * Oily
 - * Icy
 - * Wet
- Watch for loose debris, such as leaves, slippery substances or loose gravel that can hamper the stability of your vehicle.
- DO NOT exceed the legal speed limit or drive too fast for existing conditions. Always reduce speed when poor driving conditions exist. High speed increases the influence of any other condition affecting stability and increases the possibility of loss of control.
- Keep to the correct side of the road center line when meeting oncoming vehicle.
- Always sound your horn, actuate your turn signals, and exercise caution when passing other vehicles going in the same direction. Never try to pass another vehicle going in the same direction at street intersections, on curves, or when going up/or down a hill.
- At street intersection give the right-of-way to the vehicle on your left or right. DO NOT presume you have the right-of-way.
- Always signal when preparing to stop, turn or pass.
- While turning either right or left, watch for pedestrians, animals, as well as vehicles.
- All traffic signs, including manual controls at intersections, should be obeyed promptly. SLOW DOWN at traffic signs near schools and CAUTION signs at railroad crossings.

Rules of the Road

20

- When intending to turn, signal at least 100 feet (30.5 meters) before reaching the turning. Be close to the center line (unless local rules require otherwise), slow down and then turn carefully.
- Never jump a traffic light. When a change is imminent from GO to STOP (or vice versa) at intersections, slow down and wait for the light to change to green. Never run through a yellow or red traffic light.
- DO NOT leave the curb or parking area without signaling. Be sure your way is clear to enter moving traffic. A moving line of traffic always has the right-of-way.
- Park your motorcycle on a firm and flat surface to prevent it from falling over.
- Protect your motorcycle against theft. After parking your motorcycle, remove Ignition key from switch and lock the steering head.



SIDE VIEW MIRRORS



Your motorcycle is equipped with convex mirrors and have a curved surface. This type of mirror is designed to give a much wider view to the rear than a flat mirror; however, cars and other objects seen in this type of mirror will look smaller and farther away than when seen in a flat mirror.

Use care when judging the size or distance of objects seen in these mirrors.

NOTE :

To help you establish the relative distance of vehicles behind your motorcycle, adjust each mirror in such a way, that a small portion of your shoulder is visible and a large portion behind your motorcycle is seen clearly.

Vehicle Identification

21

CHASSIS NUMBER

Punched on the steering head tube

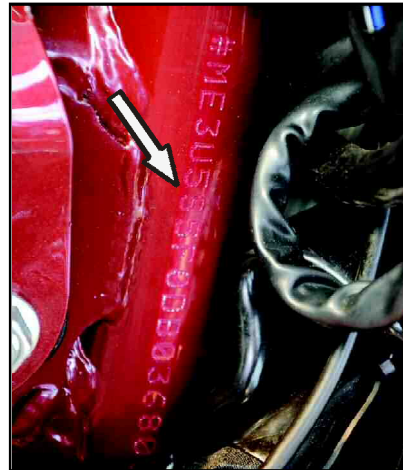

ENGINE NUMBER

Punched on top of the engine LH side.



Key Parts Location

22

RIGHT SIDE VIEW



1.	RH Trafficator front
2.	Brake Pedal
3.	Starter Motor
4.	Utility Box
5.	Air Filter Box
6.	RH Trafficator Rear

Key Parts Location

LEFT SIDE VIEW

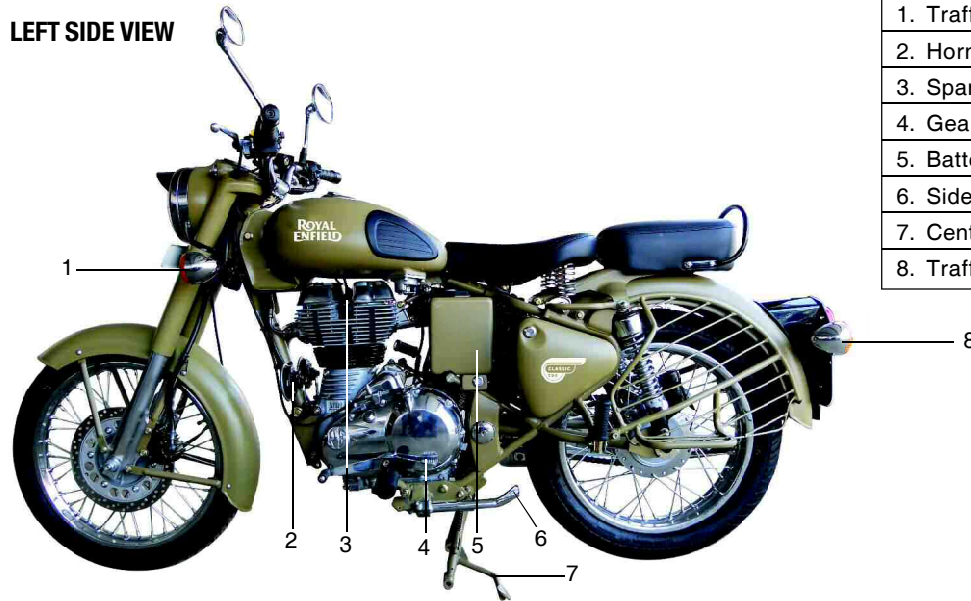

1. Trafficator front LH
2. Horn
3. Spark plug
4. Gear Change Pedal
5. Battery Cover
6. Side Stand
7. Centre stand
8. Trafficator rear LH

Key Parts Location

TOP VIEW

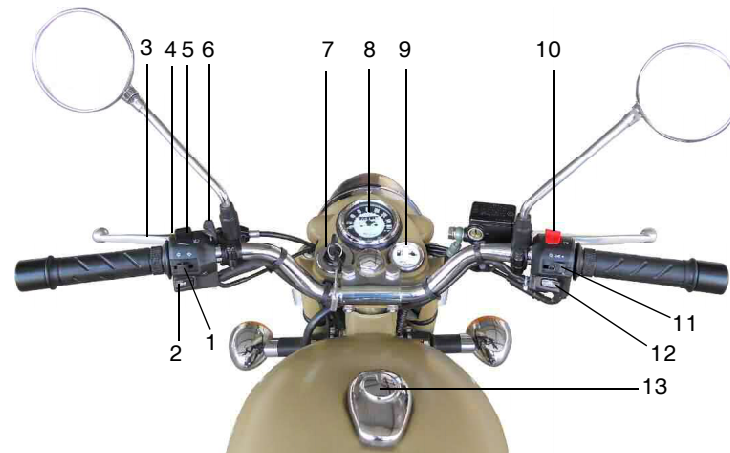

1. Turn signal switch	6. Manual Bistarter / Choke	11. Pilot head light switch
2. Horn button	7. Ignition switch	12. E-Start Switch
3. Clutch lever	8. Speedometer	13. Fuel tank cap
4. Day flash switch	9. Malfunction / Low fuel Indicator	
5. Head lamp dip switch	10. Engine Kill switch	

Operation of Controls

25

IGNITION SWITCH

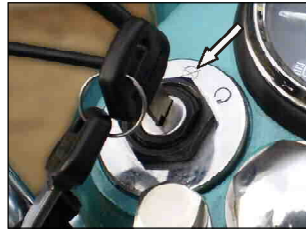

OFF



ON

STEERING LOCK



Turn key clockwise to lock.

- Lock the steering when leaving bike parked.

CAUTION :

Protect your motorcycle against theft. After parking your motorcycle, remove the ignition key from switch and lock the steering head.

DO NOT lubricate barrel locks with petroleum based lubricants or graphite. Inoperative locks may result in damage to your vehicle.

Operation of Controls

26

FUEL TANK CAP



Turn key clockwise to open.
Press cap to lock with key in position.

NOTE :

- Key can be removed only in locked position.
- Use high quality unleaded high octane petrol (91 octane and above) for enhanced performance.

SIDE BOX



SIDE BOX LH

Turn Key anti-clockwise to open



AIR FILTER BOX RH

Turn Key anti-clockwise to open

NOTE :

- Key is common for ignition, petrol tank cap, steering lock, side boxes and battery cover.
- Key for fuel tank and tool boxes can be removed from the lock only in locked

Operation of Controls

27

BATTERY CARRIER



Battery Box Cover

Turn Key clockwise & lift the battery box cover gently

UTILITY BOX

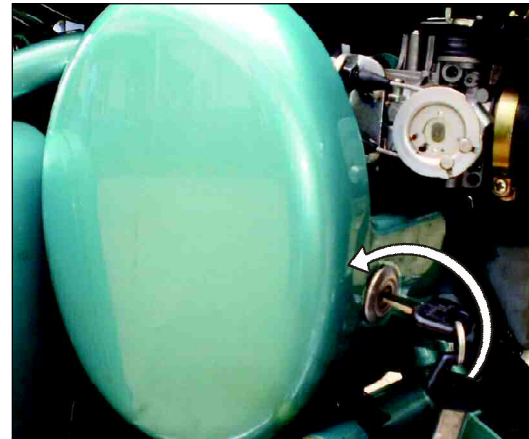

To remove cover turn key anti clock-wise and pull the oval cover by applying finger pressure

Operation of Controls

HEAD LAMP SWITCH



● HEAD LAMP OFF



☑ PILOT LIGHT ON



☑ HEAD LAMP ON

HEAD LAMP DAY FLASH



PRESS FOR HEAD LIGHT FLASH

DIP SWITCH



☑ LOW BEAM



☑ HIGH BEAM

Operation of Controls

ENGINE START SWITCH

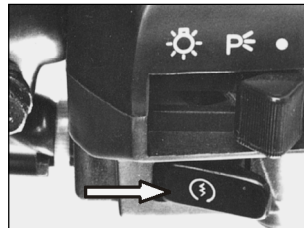

PRESS

ENGINE STOP SWITCH



ENGINE ON



ENGINE OFF

TURN SIGNAL SWITCH



OFF (PUSH TO OFF)



LEFT



RIGHT

Operation of Controls

HORN



 **PRESS**

MANUAL BI STARTER (CHOKE)

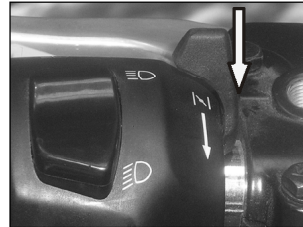

Apply choke in cold start condition while starting the Bike

Pre Operational Checks

A careful check of the following must be carried out every time before riding and specially after long periods of storage to determine if additional maintenance is necessary.

1. Tyres for correct pressure, abrasions or cuts.
2. Rear chain for proper tension.

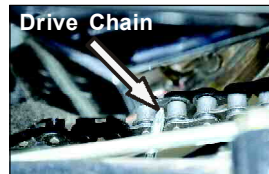

3. Brakes, steering and throttle for responsiveness.
4. Cable for fraying or crimping and free operation.

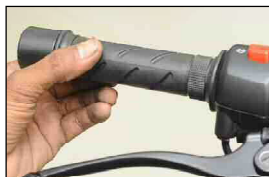

5. Engine oil level.
6. Wheel spoke for proper tightness, no breakage,

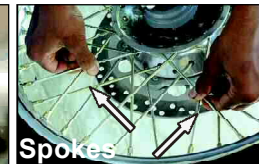

7. Headlamp, tail lamp, brake lamp and indicator lamps for proper operation.

Warning

For your personal welfare and safety, all the points mentioned above should be performed periodically. Failure to do so, may affect safe operation and damage your motorcycle and could result in an accident causing serious injury.

Running In Period

32

Proper running-in is very important for obtaining maximum life and performance of a new motorcycle. The following guidelines explain proper running-in procedures.

Since the engine is brand new, it should not be loaded excessively for the first 2,000 kms. During the first few hundred kms, the various parts in the engine wear and polish themselves to the correct operating clearances. Driving with prolonged full throttle operation, or any high speed conditions might result in excessive heating of the engine and cause abnormal wear of the moving parts and hence must be avoided.

1. 0 - 500 Kms :

The recommended speeds for the first 500 Kms is below 50 Km/h. During this period avoid operating the motorcycle with full throttle opening. Stop the motorcycle for about 5 to 10 minutes to let it cool down, after every hour of running. Vary the speed of the motorcycle regularly during running but avoid using the motorcycle above ½ throttle opening position.

2. 501 - 2000 Kms.

The recommended speed is below 80 Km/h. Avoid

driving the motorcycle with full throttle opening. Vary the speed of the motorcycle regularly but avoid using the motorcycle above ¾ throttle opening position.

3. 2,001 kms and above

Avoid prolonged full-throttle operation. Vary speed occasionally.

CAUTION :

After covering the first 500 kms. please replace the engine oil and oil filter element.

Royal Enfield engines are air-cooled and consequently require forced air cooling over the cylinders and heads to maintain proper operating temperature. Extended periods of idling may over heat the engine, resulting in serious engine damage.

DO NOT run the engine at extremely high RPM with clutch disengaged or transmission in neutral as it can cause serious engine damage.

An engine running long distances at high speed must be given close attention to avoid over heating and possible engine damage.

Electronic Fuel Injection & MIL

33

ELECTRONIC FUEL INJECTION (EFI)

An electronic control unit (ECU) monitors engine performance and provides exact requirement of Air / Fuel mixture to the engine, through the fuel injector by taking inputs from various sensors provided in the motorcycle.

THE ADVANTAGES OF EFI ARE

- Faster response of the engine to suit road/load conditions.
- Better power output
- Lower emission
- Better reliability
- Excellent cold startability
- Engine Diagnostic capabilities
- Maintenance free

MALFUNCTION INDICATOR LAMP (MIL)



A Malfunctioning Indicator Lamp (MIL) is provided in the small meter located on the right side of the head lamp casing.

There are two indications in this unit.

Low fuel indication & EFI Mal-function Indicator Lamp (MIL). When both the Ignition & Engine kill switch is "ON", the MIL will glow for few seconds and will go "OFF". This indicates that all the functions of Electronic Control Unit (ECU) and other sensors are working perfectly and the motorcycle can be used.

Incase of any malfunctioning of the ECU or other sensors etc., the MIL will glow continuously. In the event of any such phenomenon, it is recommended to take the vehicle to a nearest Royal Enfield authorised service point for inspection and further necessary action.

Rollover Sensor

34

ROLLOVER SENSOR

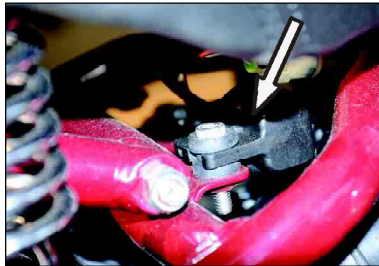

Your motorcycle is fitted with a unique “Roll Over Sensor” under rider seat. This is a safety feature.

In the event of an accident OR if the motorcycle falls over on its side with the engine running.

The “Roll Over Sensor” will switch off Ignition and cut off fuel supply to prevent the motorcycle from moving suddenly, if it is in gear.

To re-activate the system after the motorcycle has been made upright, please switch off both the Ignition & Engine kill switch, wait for a few seconds and switch “ON” again.

This will help to RESET the “Roll Over Sensor” and the engine can be started / run.

Starting

35

Warning

Before starting engine, always shift gears into neutral.

CAUTION :

Do not force the gear lever while attempting to shift to neutral. Move the motorcycle back & forth and simultaneously press gear lever to come to neutral. Ensure neutral indicator light comes "ON" in the Speedometer.

NOTE :

- If the engine does not start on the first attempt in cold climate, release the starter button, wait for 30 seconds before pressing the starter button again.
- Press starter button and release starter switch once the engine starts.
- A clutch switch is provided in the system for the safety of the rider. This is to prevent the vehicle from starting when the vehicle is in gear. To start the engine when it is in gear, pull clutch lever, press starter button and release as soon as the engine starts.



- Turn ignition switch 'ON'

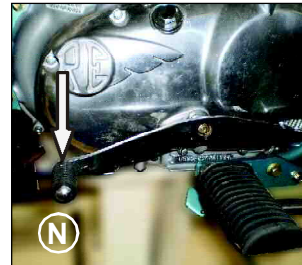

- Ensure the side and main stands are in released position
- Ensure that gears are in neutral and neutral lamp is glowing.

Starting



- Ensure Engine stop switch is in "RUN" position

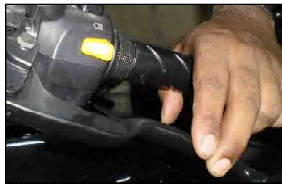

- Press Clutch Lever.



- Press Starter Button and release as soon as engine starts

CAUTION :

Never accelerate the engine immediately after a cold start. The engine should be allowed to run slowly for 15-30 seconds. This will allow the engine to warm up and let oil reach all surfaces needing lubrication. Failure to adhere may result in damage to the Engine.

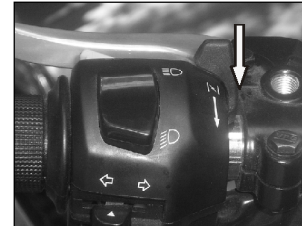

- Manual bi (choke) Starter

NOTE:

It may be necessary to operate and hold the manual bi starter, when starting the engine for the first time in cold mornings or at high altitudes, to prevent the stalling and to keep the idling RPM steady.

Starting

37

As soon as the engine attains the operating temperature, the RPM will raise, at which time the manual Bi Starter should be released.

- Warm up engine for 2 minutes - till idling is consistent.

Prior to starting, check to see if the low fuel indicator is glowing continuously.

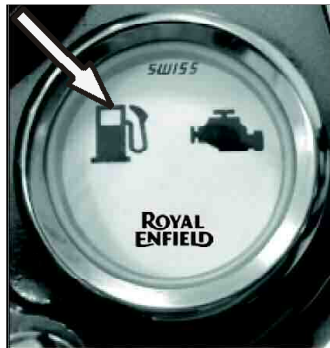

This will glow continuously, if the fuel level in tank is below 2.5 litres approx.

CAUTION :

Please ensure the motorcycle is not used with the low fuel indicator lamp "ON" continuously. It may not only result in the motorcycle running out of fuel. But will also cause serious damage to the fuel pump. Please ensure fuel is filled up as soon as the low fuel lamp comes "ON".

USING KICK START

- Slightly crank the engine further till compression eases over.



- Start the motorcycle with a powerful swinging kick.

- Release the choke, if applied

Gear Shifting

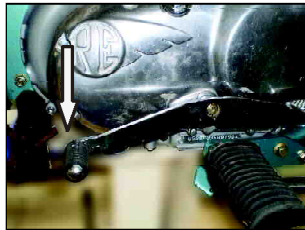

- Warm up engine for 2 minutes - till idling is consistent/stable

GEAR SHIFT PATTERN
1—N—2—3—4—5

- Press clutch lever towards the hand grip.
- Press gear pedal with toe to engage 1st gear.
- Gently open throttle and release clutch simultaneously. If clutch is released suddenly, the engine may stall and cause a jerky start.

CAUTION :

The clutch must be fully disengaged before attempting a gear shift. Failure to fully disengage the clutch may cause a jerky start and / OR stalling the engine besides causing damage to transmission parts.



- Press the gear pedal with heel to engage 2nd and higher gear.



- Follow the same procedure for 3rd, 4th and 5th gear.

NOTE :

Always start motorcycle with gear in neutral position.
Always move the motorcycle in first gear position only.
When engine speed decreases, while climbing a gradient or running at a reduced speed, shift to the appropriate lower gear to prevent the engine from stalling or straining to pull.

PARKING VEHICLE ON CENTER STAND



- Select a firm, flat surface
- Hold handle bar straight
- Lower center stand, and ensure that both the legs of the stand are resting evenly on firm ground.
- Apply pressure on the fulcrum lever on the center stand and pull vehicle backwards, gently.

PARKING VEHICLE ON SIDE STAND



- Select a firm, flat surface
- Lower Side Stand and gently tilt motorcycle to the left till it rests firmly.

Warning

Always park the motor cycle on a firm and flat surface. Parking in a soft ground may cause stand to sink and the motorcycle to fall, causing injury to you or to others and damage to the motorcycle parts.

Tools & First Aid Kit

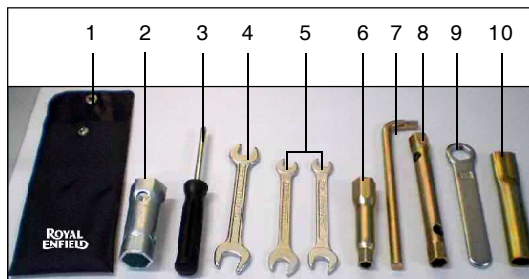

S.No.	Description	Qty.
1.	Tool bag	1
2.	Box spanner 21 X 24	1
3.	Screw driver O6 X 160	1
4.	Double end spanner 1/4 X 5/16	1
5.	Double end spanner 10 X 12	2
6.	Tool- Spark plug	1
7.	Tommy bar	1
8.	Tubular spanner 12 X 13	1
9.	Single end ring spanner - 17	1
10.	Extension tube	1

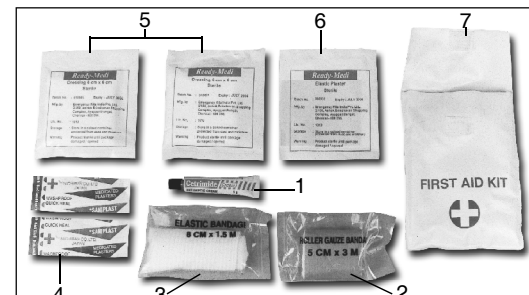

S.No.	Description	Qty.
1.	Antiseptic cream 5 gms	1
2.	Gauze bandage 5 cm x 2 cm	1
3.	Elastic Gauze bandage 8 cm x 1 mtr.	1
4.	Wash proof plaster 1.9 cm x 7.2 cm	2
5.	Sterilized Gauze Swab 5 cm x 5 cm	2
6.	Sterilized elastic plaster 7 cm x 6 cm	1
7.	First aid kit pouch	1

NOTE :

This Tool Kit is kept in Utility box. Refer Page No. 27

Recommended Lubricants

Engine Oil	
Grade	Royal Enfield 15 W 50 API SL Grade Engine Oil (JASO MA)
	
Capacity	2.75 Ltrs. (with oil filter) 2.50 Ltrs. (during oil & filter element replacement)

Front Fork Oil	
Grade	Royal Enfield Front Fork Oil (or 1F Grade Endurance)
Capacity	195 ml/leg

Brake Fluid	
Grade	DOT 3 or DOT 4
Capacity	60ml

ISO 14001 – EMS Operation Control Process
<ol style="list-style-type: none"> 1. All customers are advised timely replacement of Engine Oil, Fork Oil & Brake Oil at the dealership /ASP. In case done privately, it is advise to reach old/used Oil to our authorised vendor through RE Dealer/ASP 2. Similarly we advise for disposal of old/used Battery, Tube & Tyres as mentioned in above point No.1.



Warning

DO NOT switch oil brands indiscriminately because some oil interact chemically when mixed. Use of inferior oils or non-detergent oils can damage the engine.

DO NOT Mix DOT 3 & DOT 4 brake fluid together.

Periodical Maintenance

42

The maintenance schedule detailed here will help you to maintain your Classic 500cc meticulously and to get a long trouble free service. The schedule provided herein is based upon average riding conditions and indicates the mileage at which regular inspections, adjustments, replacements and lubrications must be carried out.

The frequency of the maintenance must be shortened depending upon the severity of the driving condition OR if the motorcycle is used in a very dusty environment, severe climatic cold and hot conditions, bad roads, stagnant water etc., Contact a nearest Royal Enfield Authorised Dealer / Service Point for expert advice and to carry out the periodical maintenance.

 **Warning**

For your personal welfare, all the listed service and maintenance recommendations should be performed. Lack of regular maintenance at the suggested intervals may affect the safe operation of your motorcycle causing the motorcycle to malfunction and stall abruptly resulting in an accident and cause serious injury.

Periodical Maintenance

43

S. No.	DESCRIPTION	FREE SERVICE				PAID SERVICE							
		whichever is earlier											
	Kms (x 1000)	0.5	3	6	9	12	15	18	21	24	27	30	
	Months	1.5	3	6	9								
1	Engine Oil	R	I	R	I	R	I	R	I	R	I	R	
	Check level at every 1000 Kms or earlier as required												
2	Engine oil filter element	R	C	R		R		R		R		R	
3	Engine sump filter (oil strainer)	C	C	C		C		C		C		C	
4	Magnetic drain plug under gear box and secondary drain plug under crankshaft in crankcase RH	C	C	C		C		C		C		C	
5	Spark plugs (2 nos.)	C&A	C&A	C&A	C&A	C&A	R	C&A	C&A	C&A	C&A	R	
6	HT leads for crack	I	I	I	I	I	I	I	I	I	I	I	
7	Fuel hose & clip/Injector 'O' Ring/Seal Ring	I	I	I	I	R	I	I	I	R	I	I	
8	Fuel Pump (under tank)	Check for screw tightness in all services											
9	Accelerator & Throttle pully cable free play	A	A	A	A	A	A	A	A	A	A	A	
10	Rubber hose, Air filter to Throttle body	I	I	I	I	R	I	I	I	R	I	I	
11	Rubber hose, Inlet manifold / Adaptor	I	I	I	I	R	I	I	I	R	I	I	

Periodical Maintenance

S. No.	DESCRIPTION	FREE SERVICE whichever is earlier				PAID SERVICE							
		Kms (x 1000)	Months										
	Kms (x 1000)	0.5	3	6	9	12	15	18	21	24	27	30	
	Months	1.5	3	6	9								
12	Air filter paper element	C	C	C	C	R	C	C	C	R	C	C	
13	Inlet / Exhaust valve seating						I					I	
14	Cylinder head (Combustion chamber)											D	
15	Clutch lever free play	Adjust every 1000 Kms or earlier as required											
16	PAV pipes & hose clip	I	I	C	I	C	I	C	I	C	I	C	
17	Rear brake pedal pivot	L	L	L	L	L	L	L	L	L	L	L	
18	Battery terminals (apply petroleum jelly)	C	C	C	C	C	C	C	C	C	C	C	
19	Battery Electrolyte level	I	I	I	I	I	I	I	I	I	I	I	
20	Earth wire eyelet (behind battery carrier)					I						I	
21	Front Fork oil / leak	I	I	I	R	I	I	I	R	I	I	I	
22	Rear Wheel Drive Chain	Adjust for every 1000 Kms / Clean, Lubricate & adjust every 3000 kms or earlier as required											
23	Rear brake pedal free play	Adjust every 1000 Kms or earlier as required											
24	Rear brake cam			L		L		L		L		L	

Periodical Maintenance

45

S. No.	DESCRIPTION	FREE SERVICE				PAID SERVICE						
		whichever is earlier										
	Kms (x 1000)	0.5	3	6	9	12	15	18	21	24	27	30
	Months	1.5	3	6	9							
25	Steering ball races / play adjustment		A	L	A	R	A	L	A	R	A	L
26	Spokes tightness / Wheel rim run out front & rear	I		I		I		I		I		I
27	Swing Arm pivot bush & spacer			L		L		L		R		L
28	Rear wheel cush rubbers					I & R				I & R		
29	Tyre wear (Front & Rear)			I	I	I	I	I	I	I	I	I
30	Brake Oil level check / Replacement	I	I	I	I	I	I	I	I	R	I	I
31	Pivot-Side Stand, Center Stand, Pillion Foot Rest	L	L	L	L	L	L	L	L	L	L	L
32	Throttle body / Injector	Carbo Cleaner / Carb Click or Fuel Line Cleaner Spray Every 6000 Kms or 6 Months whichever earlier										
33	Hand levers & kick starter lever pivot	Lubricate every 1000 Kms or earlier as required										

A : Adjust C : Clean D : De-carbonise I : Inspect L : Lubricate R : Replace

NOTE :

For maintenance after 30,000 Kms, please repeat the same frequency levels specified above, in consultation with a Royal Enfield Authorised Dealer / Service Point.

Minor Maintenance Tips

46

The following minor maintenance can be carried out easily with simple tools. However, In case, if it is felt that the adjustments are best done by an expert, we recommend that the motorcycle be taken to a nearest Royal Enfield Authorised Dealer / Service Point.

CONTROL CABLES, HANDLE BAR LEVER, PIVOTS, CENTER / SIDE STAND PIVOTS



Lever Pivot

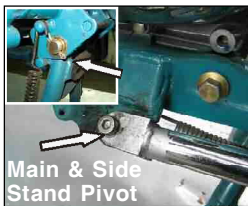

Main & Side
Stand Pivot

- Lubricate after using the motorcycle in rain, after waterwash or if used in dusty conditions.
- Wipe the area free of dirt / grease.
- Apply a few drops of oil on the pivots.

OIL LEVEL INSPECTION

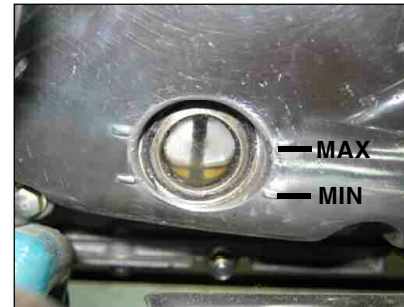

- Place motorcycle on its center stand on a firm surface.
- Warm up engine for a few minutes & switch off
- The level is correct if the oil level is in the middle of the oil level window.
- Top up with recommended oil if required.

Minor Maintenance Tips

47

ENGINE - OIL CHANGE

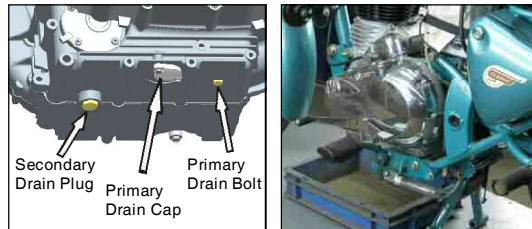

(Refer Periodical Maintenance Chart for frequency)

- Place motorcycle on its center stand on a firm flat surface.
- Start engine and warm up for 2 minutes.
- Keep a clean tray below the engine
- Remove primary drain cap, to drain oil & clean suction filter, magnet.
- Then remove secondary drain plug to drain oil & clean the magnet.
- Finally remove primary drain bolt to drain the complete oil.

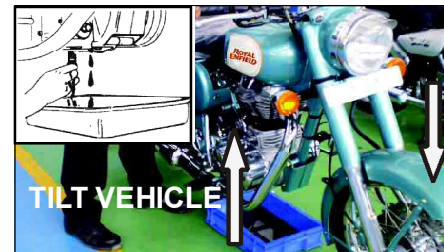

- Remove the oil filter element on the Crankcase Cover RH.
- Allow the oil to drain by tilting the motorcycle to both sides.
- Wash the primary and secondary drain plugs along with suction filter thoroughly and refit on the crankcase after all the oil is drained out.

Minor Maintenance Tips

48

- Soak a new oil filter element in the oil and refit on the Crankcase Cover RH.
- Assembly 3 bolts and tighten them. Ensure 'O' Ring and gaskets are taken seat properly.



- Fill recommended oil to engine till the oil level is upto "MAX" level mark in the oil window in Crankcase Cover RH.



NOTE :

Replace oil filter element whenever oil is being replaced.

CAUTION :

Filling up oil over MAX mark may cause smoke and / or loss of power. Do NOT allow oil level to fall below MIN mark. Doing so may result in engine internal damage or malfunction.

SPARK PLUG

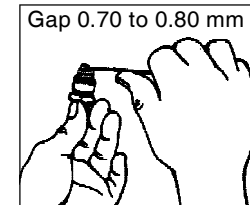
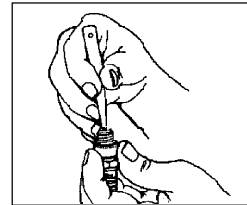

Cleaning and adjusting gap (Refer Periodical Maintenance Chart for frequency)

- Remove HT Lead and the spark plug from the cylinder head using the plug spanner and tommy bar.
- Clean the insulator tip and electrodes of the plug carefully using a pointed scraper or spark plug cleaner.
- Set the gap between 0.70 to 0.80 mm.
- Refit the spark plug on the cylinder head and connect H.T. Lead.

Minor Maintenance Tips

BRAKE FLUID

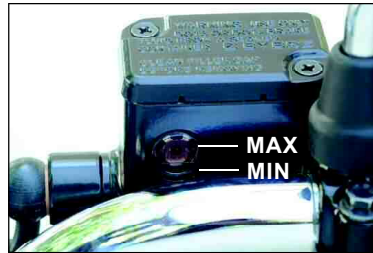

Check if oil is above 'min' level. To top up, remove cover and diaphragm and top up with either DOT 3 or DOT 4 as specified.

CAUTION :

Please take care that it does not spill over any other parts of the motorcycle. Please wipe the spilled brake fluid immediately, if there is any spill over, using a soft cloth (preferably a wet cloth) to avoid damage to paint work or other parts.

Don't mix DOT 3 & DOT 4 Brake fluid together.

INSPECTION OF TYRES AND WHEELS

- Inspect the tyre periodically for tread wear, cracks and cuts.

Minimum tread depth :	
Front tyre : 1mm	Rear tyre : 2 mm

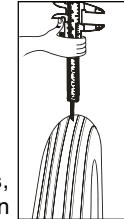

- Check and remove stone, splinters, nails or other particles embedded in the tyre treads.
- Bald spots / swelling may be caused by internal damage. Replace the tyres, if defective.
- Replace tyres when the tread depth has reached the minimum as specified.
- Periodically inspect wheels for spokes breakage and wheel rim run out.
- Check proper seating of the tyre beading on the rim whenever the tyre is reassembled.

Minor Maintenance Tips

- Whenever a new tyre is installed, ensure rim and spokes do not get damaged on account of using wrong levers.
- Use only standard tyres & tubes inflated to correct pressure.

TYRE PRESSURE

	Front	Rear
Solo	1.41 kg/cm ² (20 PSI)	2.11 kg/cm ² (30 PSI)
With Pillion	1.55 kg/cm ² (22 PSI)	2.25 kg/cm ² (32 PSI)

Warning

Tyres, rims and air valves must be correctly matched to wheel rims. See your Royal Enfield Dealer. Mismatching tyre, tubes, rims and air valves may result in damage to the tyre bead during mounting, allow tyre slippage on the rim and cause tyre failure.

FRONT WHEEL REMOVAL

- Place the vehicle on center stand

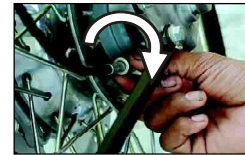

- Place a wooden block the front end of engine to support the vehicle.



- Disconnect speedo cable.

- Loosen the pinch bolt on the RH fork guide.

- Hold front axle by spanner and loosen axle nut then remove nut along with washer.

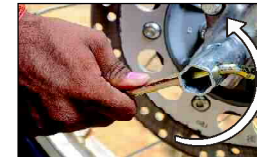
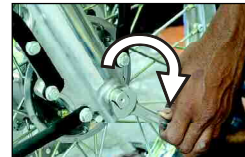

Minor Maintenance Tips

- Tap and remove the front wheel spindle.
- Tilt the vehicle to RH Side and take out the wheel along with speedo drive with bush & LH side spacer.

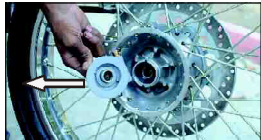

- Take out Speedo drive and bush on the RH side as shown in pic.

CAUTION :

Do not press the front brake lever when wheel is removed as this will result in the brake pads coming too far out of the brake caliper.

- Place a 4 mm thick wooden piece or cardboard sheet between the brake pads to avoid pads activation in the event the front brake lever is accidentally pressed.

FRONT WHEEL ASSEMBLY

- Remove the wooden piece / card board sheet placed between the brake pads

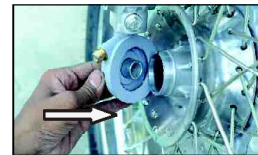

- Place the speedo drive bush in position and place speedo drive over it.

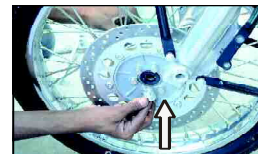

- Insert the wheel along with speedo drive assembly and LH spacer between the front fork ends ensuring the brake disc is located in between the brake pads.



- Insert and tap the front wheel axle gently inside.

- Refit the washer and tighten the nut firmly.

Minor Maintenance Tips

52

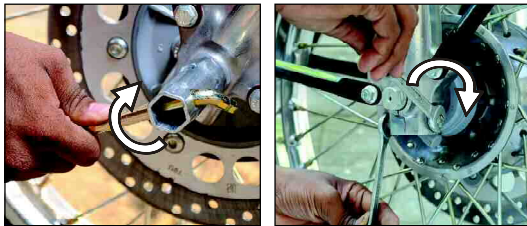

- Tighten the pinch bolt on the RH fork guide.
- Rotate the wheel and check for smooth rotation.
- Connect the speedo cable to speedo drive unit and rotate the wheel to check for proper working of speedo meter.
- Press brake lever 2 or 3 times to check front brake efficiency

NOTE :

Ensure that the speedo drive is correctly located such that the cable can be connected without difficulty.

REAR WHEEL REMOVAL

- Place the vehicle on center stand on a firm and flat surface.
- Note and mark the position of the chain adjuster butting with the stopper on the right side.



- Remove split pin and castle nut on the RH side.
- Remove wheel spindle from LH side along with chain adjuster, taking care not to drop the wheel collar and spacer from the LH side of the wheel.
- Tilt vehicle to RH side and slide out rear wheel.

Minor Maintenance Tips

REAR WHEEL ASSEMBLY

- Ensure the four cush rubbers are in position inside the rear wheel hub.

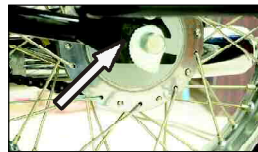

- Tilt vehicle to right and insert wheel assembly between the swing arms.
- Position the rear wheel with cush rubber on the rear chain sprocket.
- Hold wheel collar and spacer in position.
- Assemble the wheel spindle along with chain adjuster from the LH side of vehicle and gently tap it through the wheel.

- Ensure that the chain adjuster knotch butts with the stopper as appropriate when both the front & rear wheels are aligned.



- Tighten the castle nut firmly and ensure that the hole on axle shaft and the slot on castle nut are aligned to enable split pin fitment.
- Fix the split pin.

CAUTION :

Do not force the spindle into the wheel as the threads may get damaged. Tap it through the wheel gently.

Warning

Ensure the vehicle does not come off center stand while assembling / disassembling the wheel assembly. Failure to adhere could result in damage or serious injury.

Minor Maintenance Tips

ADJUSTMENTS - CLUTCH

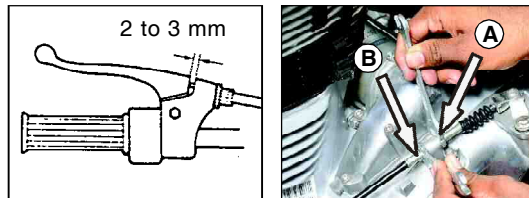

Clutch Lever (free play 2 to 3 mm)

Clutch Free Play Adjustment

- Loosen the cable outer lock nut (A).
- Turn the Nut (B) Clockwise to reduce the play or Anticlockwise to increase the free play.
- Check free play 2 to 3 mm at Clutch lever pivot on handle bar end.
- Tighten lock nut (A) after adjustment is done.

DRIVE CHAIN FREE PLAY (PLAY 25 - 30 MM)



- Remove rear wheel split pin.



- Loosen castle nut, spindle nut, anchor nut and brake rod nut.



- Turn the RH adjuster cam as appropriately, till 25 to 30 mm slackness is achieved on the top run of the chain.

Minor Maintenance Tips

- Check brake pedal free play, If necessary adjust.



- Check that the front and rear wheels are correctly aligned.
- Turn the LH adjuster cam appropriately, to align both the wheels.



- Check and ensure that the knotches on the cam are resting on the pin in the swing arm on both sides.

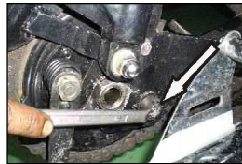

- Apply brake and tighten all nuts.
- Finally Torque the anchor Nut.

CHECKING REAR BRAKE PEDAL HEIGHT

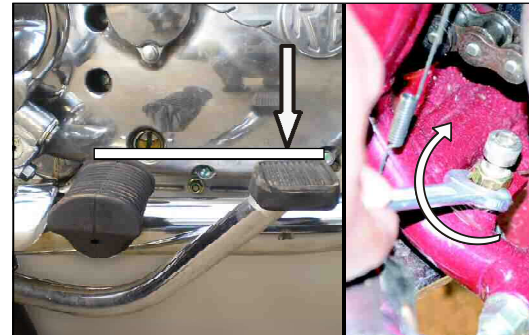

- Loosen the lock nut.
- Turn in or out the pdeal stop pin bolt till the brake pedal and front footrest are in the same height / level as shown in above fig.
- Tighten the lock nut
- Check for free rotation of rear wheel.

Minor Maintenance Tips

56

REAR BRAKE FREE PLAY ADJUSTMENT

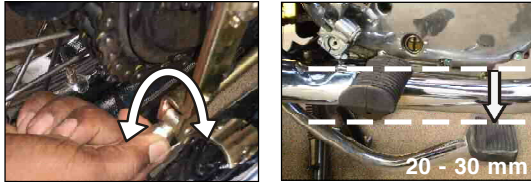

- Turn in or out the adjuster nut at the brake rod end. The recommended brake pedal travel is 20-30 mm.
- Check that the brake is not binding and the rear wheel rotates freely.

Warning

Please ensure brakes are adjusted to their maximum efficiency. Inefficient brakes can cause an accident.

Please ensure adequate caution while applying brakes. Sudden application OR pressing the levers fully can cause the wheels to lock. This may cause the motorcycle to skid with possible loss of control and result in an accident causing. Brake shoes must be inspected for wear every 4000 Kms. If you ride under adverse conditions, (steep hills, heavy traffic, etc.) a more frequent inspection at 1600 Kms or less, is required.

CHAIN LOCK FITMENT



The open end of the chain lock to face opposite to normal direction of chain rotation

Warning

The fitment in wrong direction can lead to falling off of chain link thus disengaging the drive. This will lead to potentially hazardous situation which, if not avoided, could result in serious injury.

Minor Maintenance Tips

57

ADJUSTMENT OF GAS SHOCKABSORBER

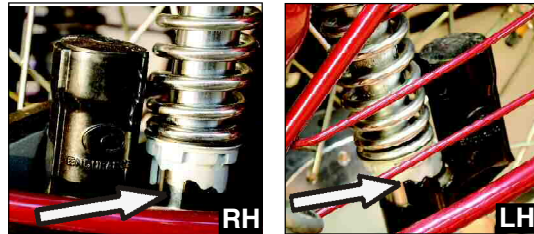

- The rear gas shock absorber is of adjustable type i.e., the spring tension can be increased or reduced.
- Increase the spring tension for high load operation.
- Reduce the spring tension for low load operation.
- The adjuster provided on the bottom of the spring has five notches.
- Insert special 'C' spanner on the bottom adjuster and rotate to change notch position.

- Turn the adjuster such that the adjuster moves up to increase the spring tension and vice versa to reduce the spring tension.
- Adjust both left hand and right hand shock absorbers so that the same notch rests on the pin in both sides.

Warning

Riding the motorcycle with the notches adjusted in different positions can cause loss of control and may lead to an accident.

Regularly inspect shock absorbers and front forks for leaks. Replace worn parts. Worn parts can adversely affect stability and handling.

NOTE :

Ensure no fouling of any accessories with rear shock absorber. Check for sufficient gap availability between the shock absorber and the attachments when the rear end of the motorcycle is fully loaded and the shock absorbers are fully compressed.

Minor Maintenance Tips

58

REMOVAL OF BATTERY FROM THE VEHICLE

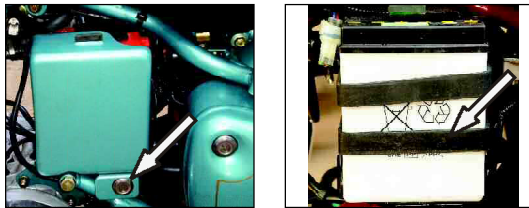

- The vehicle is provided with 12V - 14 AH battery.
- Unlock (turn the key clockwise) and remove the battery cover.
- Remove the battery holding two rubber straps gently.
- Pull out the battery and turn, then disconnect both the terminal wires (negative and positive respectively)
- Take out the battery.

BATTERY MAINTENANCE

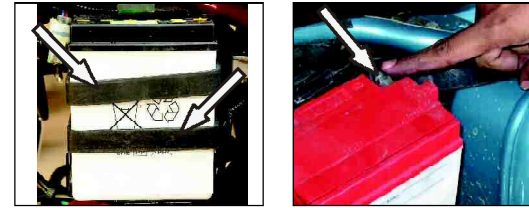

- The battery must be periodically checked for
 - Cleanliness and corrosion free terminals.
 - Electrolyte level.
 - If electrolyte level is low, top up with distilled water only.
- Apply petroleum jelly over the battery terminals to avoid sulphation.

NOTE :

Incase of poor contact or loose fitment of Battery terminals may cause the failure of ECU.

Minor Maintenance Tips

59

Warning

Always disconnect the negative (-) battery cable first and then the Red positive (+) cable while removing the battery connections.

NOTE :

For checking the battery voltage and electrolyte specific gravity, contact authorised Royal Enfield service or battery service centre.

CAUTION :

- Do not use battery with low electrolyte level as the battery internal cells will get damaged.
- Do not overfill the battery electrolyte level as it will spill out through the overflow pipe and cause corrosion to vehicle parts.
- Use only distilled water meant for use in batteries to avoid damage to battery.
- Electrolyte should not be filled when the level is between minimum & maximum levels indicated in battery as "MIN" & "MAX".

ASSEMBLY OF BATTERY ON VEHICLE

- Position the battery in the battery carrier such that the negative terminal of the battery is towards fuel pump.
- Ensure ignition switch is in 'OFF' condition.
- Connect the positive terminal (Red wire) first.
- Connect the negative terminal (Black wire) next.
- Smear the terminals with petroleum jelly. (Do not use grease).
- Refit the rubber strap bracket to hold the battery.
- Refit LH side panel.

NOTE :

Clean the wire terminals free of corrosion and keep the terminals coated with petroleum jelly.

CAUTION :

Connect the +ve and -ve cables to the respective battery terminals. Failure to do so may result in damage to the motorcycle electrical system.

Minor Maintenance Tips

CHANGING ELECTRICAL COMPONENTS HEADLAMP BULB REPLACEMENT



- Loosen the head lamp holding top screw. Then pull out head lamp assembly.



- Detach bottom lug from the head lamp housing body.



- Disconnect head lamp wire connectors Green, Orange and Blue Color terminals.



- Remove rubbergrommet from the reflector assembly



- Gently press the bulb holding U clip from both the sides downwards and release it from reflector slot as shown.



- Pull out head lamp bulb and inspect its filament for fuse

CAUTION :

Never touch the bulb with your fingers, Finger prints will etch the glass and decrease bulb life. Always hold the bulb with paper or clean dry cloth during handling.



Minor Maintenance Tips

61

ASSEMBLING THE HEADLAMP

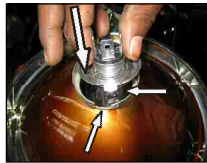

- Refix the new head lamp halogen bulb into reflector unit by locating the wide protrude on top side mounting.



- Fix bulb holding 'U' clip into reflector body notch, then press the both ends of clip and lock in its slot.



- Fit the rubber grommet.



- Connect the wire couplers as mentioned below

TOP SIDE: GREEN COLOUR
RIGHT SIDE: BLUE COLOUR
LEFT SIDE: ORANGE COLOUR



- Position the reflector ring bottom lug into head lamp casing slot and slide it, then tighten the top mounting screw.

NOTE :

After connecting above said procedure, turn ignition switch to "ON" condition and then check, ensure that flash light working in HIGH BEAM mode.

If you use the bulb other than specified rating (12V 55/60W) may result in over loading electrical system lead to premature failure or frequent battery discharge.

Minor Maintenance Tips

TAIL LAMP BULB REPLACEMENT

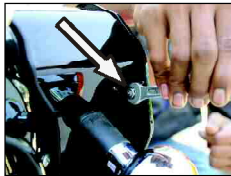

- Remove the two nuts each from RH & LH side of the rear number plate holder.
- Pull out Tail Lamp assembly along with bracket and twist the bulb holder in anticlockwise to remove bulb holder assembly.
- Turn old bulb to remove and replace with a new bulb.
- Refit the bulb holder and turn clockwise to lock the bulb holder.
- Refit the tail lamp with bracket on the reverse order of removal process.

TRAFFICATOR BULB REPLACEMENT

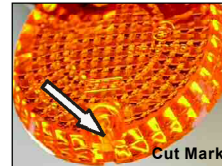

- Remove the 2 screws & take out trafficator glass cover.
- Press bulb gently & Turn anticlockwise to take out the bulb.
- Position the new bulb inside the holder, ensuring that the pins in the bulb, match with the slots in the holder.
- Press the bulb and turn clockwise to lock the bulb in the holder.
- Refit the trafficator cover cut slot mark facing downwards and tighten the 2 screws.

Minor Maintenance Tips

FUSE

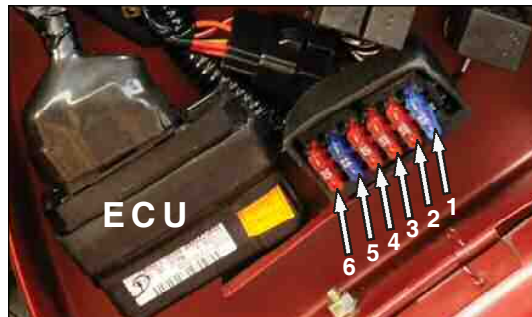

- Open the LH tool box Ref. Page No. 26.
- The fuse holder is located inside with 4+2 fuses.
- Replace the required fuse with the spare fuse available in the fuse carrier.

Please ensure to replace a spare fuse in the holder at the earliest opportunity.

BLADE FUSE USAGE LIST

Fuse No.	Color	Remarks
1	Blue	Main Fuse (15A)
2	Red	EFI / ECU Fuse (10A)
3	Red	Lighting Circuit Fuse (10A)
4	Red	Signaling Circuit Fuse(10A)
5	Blue	Spare Fuse (15A)
6	Red	Spare Fuse (10A)

Warning

Electronic Control Unit (ECU) may fail due to

- a. Loose electrical / sensors wire connectors / couplers or Battery terminals.
- b. While doing Arc welding on Motorcycle, it is recommended to "SWITCH OFF" ignition and disconnect the Battery terminals & ECU coupler from Main Wiring Harness.

Minor Maintenance Tips

AIR FILTER PAPER ELEMENT

CLEAN AND REFIX : EVERY 3000 KMS



- Insert the key, turn anti clockwise to remove RH side air filter box lid.



- Loosen the filter box cover holding nut by 10mm spanner as shown in pic.



- Remove the nut, washer and box cover, top cover filter to take out air filter element.

- Tap the air filter element to remove dust as shown and clean thoroughly before assembly.



Clean intake duct and inside filter box as shown in pic.



- Assemble the filter element, top cover and filter box cover in the reverse order of dismantling process.
- Please ensure proper sealing of cover against air filter element / box.

Pillion Seat Removal & Refitting

65

PILLION (REAR) SEAT REMOVAL



(A) Loosen front mounting nut of the rear seat under the rider seat with 12mm tubular spanner.

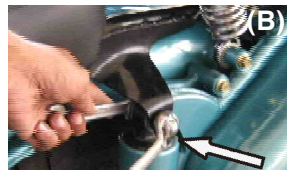

(B) Loosen both LH and RH shock-absorber top mounting nuts by holding the bolt with 3/8" x 15/16" double end spanner and turning the doom nut with 17mm eyelet spanner

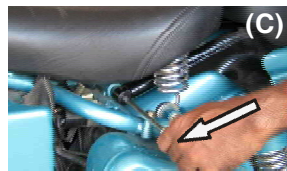

(C) Pull out the front mounting bolt of the rear seat from the bracket under the rider's seat.



(D) Pull the rear seat with its sub frame towards back so that it will become free from the shock absorber mounting bolts.



(E) Take out the rear seat sub assembly

(F) Re-tighten the shock absorber mounting bolts & nuts before using the vehicle.

Pillion Seat Removal & Refitting

66

PILLION (REAR) SEAT REFITTING



(A) Loosen shock absorber upper mounting nuts and place the pillion seat in the position over the rear mudguard, inserting the front end of its sub frame goes to its mounting under the rider's seat.

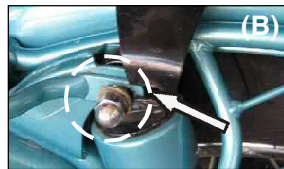

(B) Ensure the slit of rear mounting brackets are seated properly in the LH & RH shock absorber mounting bolts.

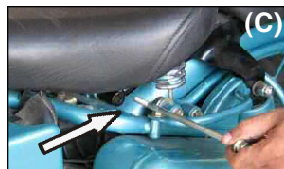

(C) Insert the front mounting bolt through the bracket under the rider seat.



(D) Tighten the front mounting nut with 12mm tubular spanner holding the bolt with 13mm double end spanner from other side.



(E) Tighten both LH & RH rear shock absorber top mounting bolt and nuts.

Washing Procedure

67

PRECAUTIONS

- Wash vehicle when the engine is cold.
- Cover the silencer tail end and control switches with suitable plastic bags and tie it firmly to prevent water entry into them.
- Remove ignition key and seal key hole using adhesive tape.
- Use a suitable engine degreaser, available with your local parts store, to remove dirt or grease from the engine external parts if required. Follow the directions in the label carefully before using the degreaser.
- Use low pressure jet of water to clean the entire vehicle.
- Never spray water with great force on head lamp, speedometer, trafficator lights, front and rear wheel hubs, electrical connections and wires, control cables, EFI components, sparkplug, battery, etc.
- Use luke warm water and mild detergent on the painted components to remove dirt, etc.
- Rinse vehicle thoroughly with plain water to remove the detergent and wipe vehicle dry.
- If possible, use compressed air and blow off water particles from the obscure areas of the vehicle, electrical connections, EFI components etc.

AFTER WASHING

- Ensure, the vehicle is thoroughly dry by wiping with a clean soft absorbent cloth or chamois leather.
- Remove all plastic bags and adhesive tapes.
- Lubricate control cables, pivot and rear chain with lube oil
- Polish the painted surfaces using polishing wax.
- Start the bike allow engine to idle and warm up.
- Drive the motorcycle slowly, applying both brakes intermittently to dry up the brake shoes.
- Test brakes for full efficiency.



Warning

Observe warnings and cautions given on labels of cleaning compounds.

When washing your motorcycle, be careful not to get the brakes, engine, mufflers or air cleaner etc., too wet.

Storage Precautions

68

Incase your Motorcycle is not going to be used for a month or more, we advise the following precautions to be taken.

- Carryout required repair / adjustments on the motorcycle.
- Wash the motorcycle thoroughly and lubricate as per the maintenance chart.
- Start the engine, warm up for a few minutes and switch off.
- Drain out the fuel completely from the fuel tank and fuel lines.
- Remove spark plug. Pour in about 25ml of clean engine oil through spark plug hole. Close the hole and crank engine several times and refit sparkplug.
- Clean rear chain thoroughly and apply a thin film of lube oil.
- Remove battery from the bike. Clean the terminals free of corrosion.
- Maintain electrolyte level between max or min mark, by adding distilled water and wipe the battery dry.
- Store the battery in a cool, dry and well ventilated place.
- Do not place the battery in direct sun light, near open flame or where temperature is above 40°C or below 0°C
- Cover the silencer with plastic bags to prevent moisture entry. Set the motorcycle on its center stand.
- Apply anti rust solution on **all chrome plated parts**. Take care not to apply this solution on rubber or painted parts.
- Store motorcycle in a clean covered area free - of moisture and keep it covered to prevent dust settling on it.

Storage Precautions

69

PREPARING THE MOTORCYCLE FOR REUSE

- Remove anti rust solution from **all chrome plated parts** and clean the motorcycle.
- Inflate the tyres to the correct tyre pressure.
- Ensure battery is fully charged and proper electrolyte level is maintained.
- Connect the battery.
- Lubricate all control cables and pivots.
- Check proper level of oil in engine.
- Fill fuel tank with fresh petrol.
- Check fuel line for any cracks or cuts.
- Clean the air filter.
- Remove plastic covering from the silencer.
- Remove spark plug on cylinder head and pour

in a few drops of engine oil. Crank engine a few times to lubricate cylinder walls and piston. Clean spark plug and refit.

- Switch "ON" ignition switch.
- Start vehicle and warm up engine for a few minutes before riding the vehicle.

NOTE :

Do not raise the engine rpm the moment it is started, but allow the engine to run at idling speed.

CAUTION :

Proper long-term storage is important for the safe, trouble-free operation of your Royal Enfield motorcycle.

Long Trip Precautions

70

CHECKS PRIOR TO THE COMMENCEMENT OF LONG JOURNEY

- Service the motorcycle thoroughly at Royal Enfield Dealer / Authorised Service Point as per periodical maintenance chart. (Ref. Page No. 43, 44 & 45)
- Sufficient quantity of petrol in the fuel tank for the journey planned.
- Check and correct tyre pressure if necessary.

CHECKS AFTER EVERY 1500 KMS OF RUN

- Tightness of all fasteners.
- Tyre tread condition and wear of tyres.
- Battery condition and electrolyte level.
- Correct oil level in engine.
- Working of all lights and horn.
- Proper drive chain tension.

ITEMS TO BE CARRIED

- Tool kit.
- First aid kit.
- Bulbs for Headlight, Trafficator light, Rear Tail Lamp and Blade Fuse (10 & 15 Amps).
- Accelerator, Choke, Clutch and Speedo Cable.
- Rear chain master link lock assembly.
- Spare tube, puncture repair kit - cold vulcanising type.
- Foot operated Air Pump.
- Insulation tape.
- Spark plugs (M14 & M10), Fuel hose.

Complete Wiring Diagram

71

NOTE :

Complete Wiring Diagram is attached on this page.

VEHICLE STARTING PROCEDURE

Basic Guidelines to be followed "FOR ALL ELECTRIC START VEHICLES"

1. When ignition key is switched "ON", please wait until the malfunction indicator lamp (MIL) goes off, before attempting to start.
2. In cold condition of the engine or for initial start, it is advised to use electric start (ES) only.
3. Apply choke in cold start condition. (ambient temperature <25°C)
4. **DO NOT ATTEMPT – "HALF START" BY CASUALLY PRESSING ELECTRIC START BUTTON.**
5. **PLEASE PRESS AND HOLD ELECTRIC START BUTTON FOR ATLEAST 3 SECONDS CONTINUOUSLY FOR THE CRANKING OR UNTIL THE ENGINE FIRES AND SUSTAINS, WHICHEVER IS EARLIER.**
6. If engine doesn't start in the first attempt, release the ES button and repeat the above procedure.
7. It is advised not to apply excessive throttle during starting.

Complete Wiring Diagram - Classic 500

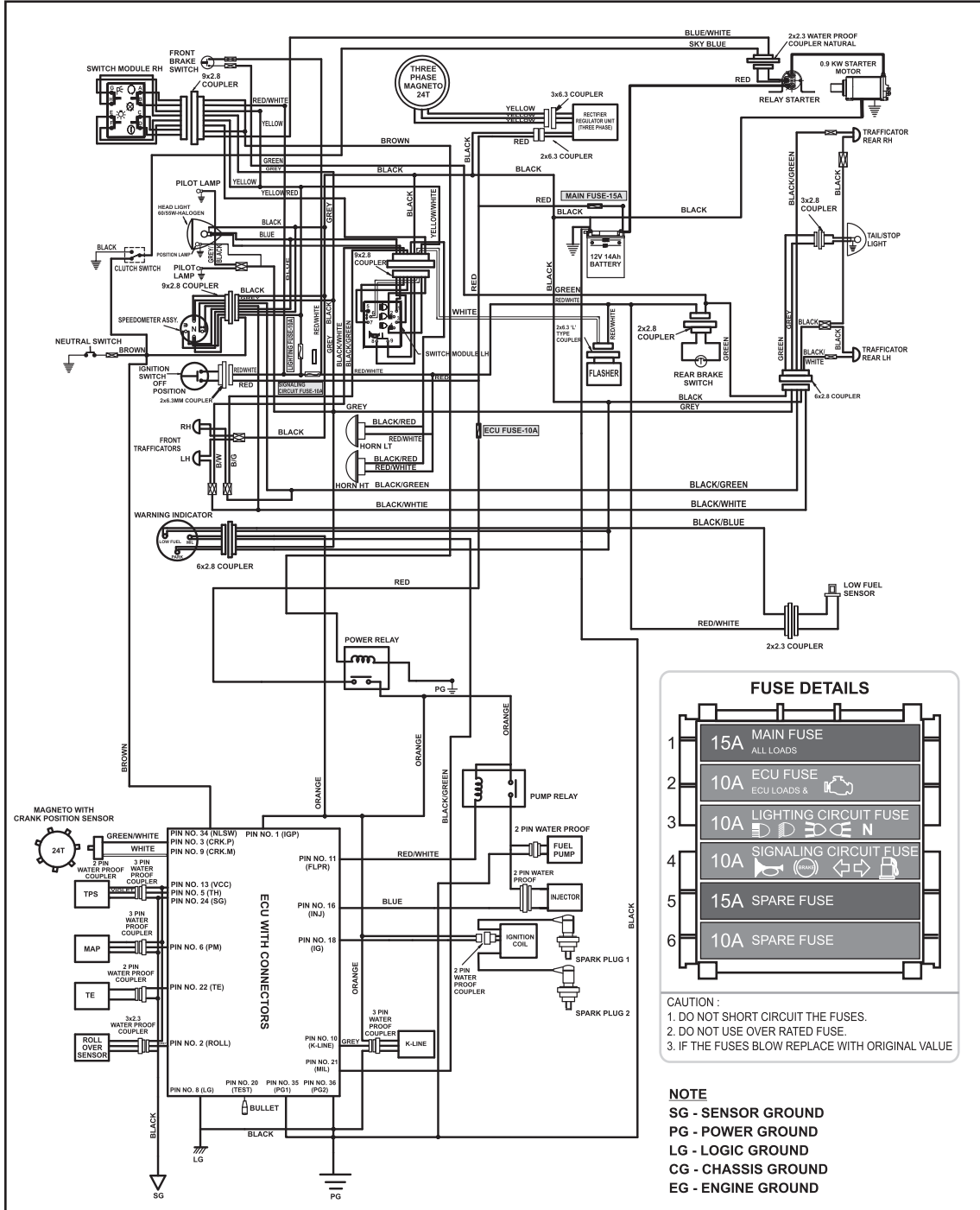

Trouble Shooting

 **Warning**

The trouble shooting section of this Owner's Manual is intended solely as a guide to diagnosing problems. Carefully read the appropriate sections of this manual before performing any work. Repair and maintenance operations not listed in this Owner's Manual should be performed by your Royal Enfield Dealer only. Improper repair and/or maintenance could result in the motorcycle not functioning properly or serious injury.

 **Warning**

Electronic Control Unit (ECU) may failure due to the following reasons.

- a. In case of loose electrical / sensors wire connectors / couplers or Battery terminals.
- b. While doing Arc welding on Motorcycle, its is recommended to "SWITCH OFF" ignition, disconnect the Battery terminals & ECU from Main Wiring Harness.

CAUSES

REMEDIES

I. ENGINE FAILS TO START

- | | |
|---|------------------------------------|
| 1) Stop switch in 'OFF' Position | Push stop switch to 'ON' position. |
| 2) Vent hole clogged in fuel tank cap .. | Clean vent hole. |
| 3) Spark plug cap / lead not connected | Fix cap / lead firmly |
| 4) Spark plug electrode dirty / fouled .. | Clean spark plug |
| 5) Spark plug insulation cracked | Replace spark plug |
| 6) Clutch slipping | * Adjust clutch cable free play |

* Contact Authorised Dealer / Service Point

Trouble Shooting

CAUSES

REMEDIES

II. ENGINE MISFIRING

- | | |
|---------------------------------------|---|
| 1) Water in petrol tank | * Clean petrol tank. Fill tank with fresh petrol. |
| 2) Loose spark plug cap | Fix cap / lead firmly |
| 3) Spark plug fouled | Clean spark plug or non specified heat range plug. |
| 4) Any sensor loose connections | * Check MAP or EOT or TPS sensor wiring/coupler loose connections |

III. POOR PICKUP

- | | |
|--|---------------------------------|
| 1) Accelerator cable free play excessive | Adjust cable free play |
| 2) Choked air filter | Clean / Replace air filter |
| 3) Brakes adjusted too tight | * Re-adjust properly |
| 4) Rear chain adjusted too tight | * Re-adjust properly |
| 5) Clutch Slipping | * Adjust clutch cable free play |
| 6) Under inflated tyres | * Inflate to correct pressure |

* Contact Authorised Dealer / Service Point

Trouble Shooting

CAUSES

REMEDIES

IV. WHITE/BLUE SMOKE

- | | |
|---|--|
| 1) Oil level in sump above the Top line.
in the oil level window | * Check and drain excess oil
* Worn out valve stem oil seal |
|---|--|

V. ENGINE OVERHEATING

- | | |
|----------------------------------|--|
| 1) Cylinder fins not clean | Clean the cylinder fins at regular intervals |
| 2) Clutch slipping | * Check and correct |
| 3) Low engine oil level | Check and top-up if necessary |

VI. EXCESSIVE FUEL CONSUMPTION

- | | |
|--|-----------------------------|
| 1) Fuel leakage | * Check and rectify |
| 2) Choked air filter | Clean / Replace |
| 3) Under inflated tyres | Inflate to correct pressure |
| 3) Sticky (Choke) Bi-starter valve | * Check and rectify |

* Contact Authorised Dealer / Service Point

Trouble Shooting

CAUSES

REMEDIES

VII. BRAKES POOR

- | | |
|--|-----------------------------------|
| 1) Not adjusted properly | * Adjust properly |
| 2) Oil/grease on lining or drum or disc. | * Clean and refit |
| 3) Linings worn / Uneven wear | * Replace linings |
| 4) Drums / Disc - scored / Uneven wear | * Rectify or Replace drums / disc |

VIII. VEHICLE WOBBLER

- | | |
|-------------------------------------|-----------------------------|
| 1) Wheel rim runout..... | * Rectify |
| 2) Loose / Broken spokes | * Tighten / Replace spokes |
| 3) Tyres not fitted correctly | * Refit tyres correctly |
| 4) Wheels misaligned | * Ensure proper alignment |
| 5) Under inflated tyres | Inflate to correct pressure |

IX. ELECTRICALS

Bulbs do not glow

- | | |
|--------------------------------------|---------------------|
| 1) Loose / improper connection | * Check and correct |
|--------------------------------------|---------------------|

* Contact Authorised Dealer / Service Point

Trouble Shooting

76

CAUSES

- 2) Bulb fused
- 3) Fuse blown

Horn not working

- 1) Loose connections
- 2) Fuse blown

Trafficators not working

- 1) Loose / improper connections
- 2) Bulb fused
- 3) Fuse blown

Brake light remains on

- (1) Switch link not adjusted properly
- (2) Switch sticky

X. ELECTRONIC FUEL INJECTION (EFI)

Malfunctioning Indicator Lamp (MIL) glowing continuously

- (1) Sensor Coupler Loose Connection .
- (2) Any EFI Sensor Failure

REMEDIES

- * Replace bulb
- Check and Replace fuse

- * Check and correct
- Check and Replace fuse

- Check and correct
- Replace bulb
- Check and Replace fuse

- * Adjust connecting links properly
- * Replace switch

- * Check for any EFI sensor coupler loose connection and correct them
- * Check & replace the same

* Contact Authorised Dealer / Service Point

Warranty

77

Royal Enfield Motor Cycles are manufactured by following best Quality practices in respect of the material and workmanship.

Royal Enfield (RE) warrants Classic 500 EFI Motor Cycle to be free from manufacturing and material defect under normal use subject to following conditions.

1. RE will replace or repair defective part / parts at their Authorised Dealer / Service Point, free of charge within a period of 12 months from the date of sale (date of Installation) or 10,000 kms whichever occurs earlier.
2. The warranty is applicable only to first registered owner.
3. The warranty shall be applicable only if all the free services are availed at the respective period / kilometer range as per the schedule given in the owner's manual from RE Authorised Dealer / Service Point.
4. During the warranty period, RE's obligations shall be limited to repairing / replacing free of charge such part or parts of the vehicle, which on examination to have manufacturing defect. Such defective part / parts which have been replaced becomes property of RE.
5. Cost of oil, oil filter, fuel and other consumables are chargeable to the customer.
6. Claims on proprietary items like tyres, tubes, spark plug, battery etc. should be taken up with respective manufacturer or their authorised agents in the area directly by customer. RE shall not be liable in any manner to replace them though their Dealers will provide assistance in preferring such claims on their manufacturer.
7. Warranty shall not apply to:
 - (a) Normal ageing, deterioration or rusting of plated parts paints coat, rubber parts, soft items, glass items, plastic parts etc.

Warranty

78

- (b) Components like fuel filter, oil filter paper element, control cables, brake shoes / brake pads, clutch plates, drive chain & sprocket kit, which are subjected to normal wear and tear.
 - (c) Damages due to use of lubricant / oil / grease etc., other than specified by RE.
 - (d) Damages due to use of non-genuine parts.
 - (e) Damages due to lack of proper maintenance of the vehicle.
 - (f) Damages due to incorrect driving or riding habits.
 - (g) Parts damaged due to accidents, collision, abuse etc.
 - (h) Irregularities not recognized as affecting the quality or function of the vehicle such as slight vibration, oil leakage, discoloration of exhaust bent pipe / silencer / soft or hard shock absorber etc.
 - (i) Defects arising from fitment of unauthorised / additional Electrical loads.
 - (j) Vehicle serviced / repaired at unauthorised service points.
 - (k) Vehicle used for competition / racing.
 - (l) Electrical component like bulbs, fuses etc. & Electronic components failure due to repairs by arc welding.
 - (m) Normal maintenance operations like adjustment of brakes, cleaning fuel system, engine tune up and other such adjustments
8. RE reserves the right to finally decide on all warranty claims
9. RE reserves the right to make changes in Design of the vehicle without any obligation to install these changes on previously supplied vehicles.

Note: Scratches or marks cannot be removed, No warranty for DESERT STORM Colour.

Emission Warranty

79

In compliance with the provisions of Rule 115(2) of the Central Motor Vehicle Rules, 1989, Royal Enfield certifies that the following warranty is applicable to those components liable to affect the emission of the gaseous pollutants in its range of motorcycles, in normal use to which it may be subjected to.

This emission warranty comes into force from 01st July 2001 and is valid for a period of 30,000 Kms. or 36 months, whichever occurs earlier, from the date of sale to the first customer and is in addition to and parallel to the warranty policy, conditions and obligations laid down in the Owner's Manual.

Royal Enfield further warrants that if on examination by its Authorised Dealer / Service Point, the motorcycle fails to meet the specified emission standards, then the Authorised Dealer / Service Point shall take necessary corrective measures and shall at its sole discretion, repair or replace free of charge such components of the emission control system to meet the required emission standards.

The method/s of examination to determine the warranty conditions of the emission warranty related components will be at the sole discretion of Royal Enfield and / or our Authorised Dealer / Service Point and results of such examination will be final and binding. If on examination the warranty conditions of the part/s is/are not established, Royal Enfield will have the right to charge all, or part of the cost of such examination to the customer in addition to the cost of the components.

In case of acceptance of the component/s under Emission warranty, Royal Enfield will replace free of charge, the component/s as required. However, the consumables like fuel, lubricants, solvents, etc shall be chargeable to the customer as per actual.

In case any of the components covered under emission warranty or the associated parts, are not independently replaceable. Royal Enfield will have the sole discretion to replace either the entire assembly or parts of the assembly, through suitable repairs.

Emission Warranty

80

Royal Enfield reserves the right to carry out necessary consequential repairs to the motorcycle or replace any part, in addition to the repair or replacement of the components covered under emission warranty, to establish compliance to in-use emission standards. Such repairs / replacements will be chargeable to the customer.

All parts removed for replacement under warranty will become the property of Royal Enfield.

Royal Enfield will not be responsible for the cost of transportation of the motorcycle to the nearest Authorised Dealer / Service Point OR for any loss due to non availability of the motorcycle during the period of examination and repairs by Royal Enfield and / or their Authorised Dealer / Service Point.

Royal Enfield will not be responsible for any penalties that may be charged by statutory authorities on account of failure to comply with the in-use emission standards.

That cost/s incurred to check emission of the motorcycle will have to be borne by the customer.

Emission warranty will be applicable irrespective of the change of ownership of the vehicle provided all the conditions as laid down in this document are met from the date of original sale of the motorcycle.

THE WARRANTY SHALL APPLY IF THE CUSTOMER

- Observes all the important instructions and any other precautions listed in the owner's manual.
- Under all circumstances uses lubricants and fuel as recommended by Royal Enfield.
- Regularly obtains and carries out maintenance in accordance with Royal Enfield guidelines and enters the details in the Log book.
- Immediately approaches the nearest Authorised Dealer / Service Point upon discovery of failure to comply with the IN-USE emission standard inspite of having maintained and used the vehicle in accordance with the instructions in the owner's manual and having carried out such repairs and adjustments as may be required with a view to establish such compliance.

Emission Warranty

81

- Produce the 'Pollution Under Control' certificate valid for the period immediately preceding the test during which the failure is discovered, the test having been carried out either for obtaining a new certificate or pursuant upon being directed by an officer as referred to in sub rule (2) of rule 116 of the Central Motor Vehicles Rules (CMVR).
- Produce the Owner's Manual and Log book for verification details.
- Produce receipts covering maintenance of the motorcycle as specified in the owner's manual from the date of original purchase of the vehicle.
- Produce valid certificate of Insurance and R.T.O. Registration Certificate (RC Book).

THE EMISSION WARRANTY SHALL NOT APPLY IF

- A valid "Pollution under control" certificate is not produced.
- The motorcycle is not serviced by Authorised Dealer / Service Point as per the service schedule described in the maintenance chart.
- The motorcycle has been subjected to abnormal use, abuse, neglect and improper maintenance or has met with an accident.
- Replacement parts not specified and approved by Royal Enfield have been used.
- The motorcycle, or parts thereof, has been altered, tampered with or modified or replaced in an unauthorised manner.
- The odometer is not functioning or the odometer and / or its reading has been changed / tampered with, so that the actual distance covered cannot be readily determined.
- The motorcycle has been used for competitions, races, and rallies or for the purpose of establishing records.

Emission Warranty

82

- On examination by Royal Enfield or its Authorised Dealer / Service Point, if the motorcycle shows that any of the conditions stipulated in the Owner's manual with regard to use and maintenance have been violated.
- The motorcycle has been run on adulterated / leaded fuel or lubricant other than those specified by Royal Enfield in the Owner's manual or any other document given to the customer at the time of sale of the motorcycle.
- The emission related components are tampered with.
- All service and parts related bills and vouchers incurred during the tenure of the emission warranty is not produced.
- All maintenance activities carried out on the vehicle during the tenure of the emission warranty is not entered in the log book.

TIPS TO BE ON THE RIGHT SIDE OF LAW

- Always get your vehicle checked to meet the emission regulations through and authorised emission checking centre.
- Always carry a valid 'Pollution Under Control' certificate with you at all times during the validity of the emission warranty (30,000 Kms / 3 years from the date of first sale)

TIPS TO REDUCE POLLUTION

1. Ensure that the periodical maintenance is carried out as stipulated in the owner's manual through a Royal Enfield Authorised Dealer / Service Point.
2. Use only Unleaded petrol (> **91 octane**) from reputed fuel pumps.
3. Ensure the fuel used is not adulterated.
4. Use correct spark plug as recommended in the owner's manual.
5. Use lubricants as per recommendations given on grade / brand in the owner's manual.

All India Road Signs

MANDATORY SIGNS



INFORMATION SIGNS



CAUTIONARY SIGNS

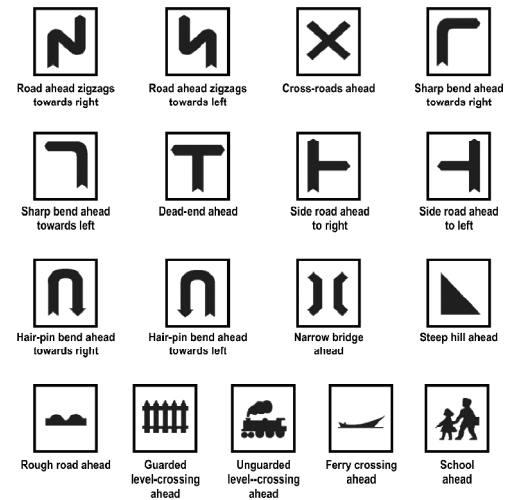

Free Service Coupons

84

It is our endeavour to provide excellent service to your Royal Enfield Motor Cycle at all times. Towards this we provide four free services at specific Intervals.

Please avail these services at the specified time, in any of the Royal Enfield Authorised Dealer / Service Point nearest to you and as a token of satisfactory service, kindly return the free service coupon duly filled in and signed, to the service outlet.

Availing the free services in the specified time is a prerequisite to warranty consideration.

The cost of fuel, oil, oil filter element, grease etc. used for free service is chargeable to the customer.

1st Free Service

85

**1ST
FREE
SERVICE**

500 Kms
or
45±8 days
whichever is
earlier from the
date of sale

Enter the Details
in Free Service
Record

(Cost of oil,
oil filter element
and other
consumables
used are
chargeable to
the customer)

500 KMS OR 45±8 DAYS WHICHEVER IS EARLIER FROM DATE OF SALE	
Customer Name :	Dealer Code : <input type="text"/>
Address :	
Frame No: <input type="text"/>	Regn. No: <input type="text"/>
Engine No: <input type="text"/>	Sale Date: <input type="text"/>
Vehicle Installation Form No. <input type="text"/>	Serviced Date: <input type="text"/>
ODO Reading : <input type="text"/>	Serviced by (Dealer's/ASP Name & Address)
Sold by (Dealer's Name & Address)	
Received the above vehicle after the service having been done to my entire satisfaction.	
Customer's Signature :	Date : <input type="text"/>
Contact Phone / Mobile No.: <input type="text"/>	

1st Free Service Activities

1. Water wash the vehicle and dry it with a clean cloth
2. Electrolyte Check level & top-up
3. Battery terminals Clean and apply petroleum jelly
4. Drive chain free play Check, clean, lubricate & adjust
5. Rear brake pedal pivot..... Lubricate
6. Rear brake..... Adjust
7. Wheel rim front & rear..... Check spokes tightness
8. Front brake Check & top up brake fluid level
9. Front fork oil leak Check for leak
10. Air filter element Clean
11. Spark plugs (2 Nos)..... Check, clean & adjust gap
12. H.T. Leads Inspect for cracks
13. Fuel pump Check mounting screws
14. Fuel hose Inspect for cracks
15. Rubber hose, Air filter to throttle body..... Inspect for cracks
16. Accelerator cable Adjust play
17. Clutch cable Adjust play
18. Engine oil sump strainer Clean
19. Engine oil Replace
20. Engine oil filter paper element Replace
21. Hand levers & kick starter pivot..... Lubricate

CUSTOMER COPY

Job Card No:

--	--	--	--	--	--	--	--

Date :

--	--	--	--	--	--	--	--

Odo Reading :

--	--	--	--	--	--	--	--

Name of Dealer/
ASP with Code:

.....
.....

ASP / Dealer's
Stamp & Signature

2nd Free Service

2ND FREE SERVICE

3000 Kms
or
90±15 days
whichever is
earlier from the
date of sale

Enter the Details
in Free Service
Record

(Cost of oil,
oil filter element
and other
consumables
used are
chargeable to
the customer)

3000 KMS OR 90±15 DAYS WHICHEVER IS EARLIER FROM DATE OF SALE

Customer Name :

Dealer Code :

Address :

Frame No:

Regn. No:

Engine No:

Sale Date:

Vehicle Installation Form No.

Serviced Date:

ODO Reading :

Serviced by
(Dealer's/ASP Name & Address)

Sold by (Dealer's Name & Address)

Received the above vehicle after the service having been done to my entire satisfaction.

Customer's Signature :

Date :

Contact Phone / Mobile No.:

2nd Free Service Activities

1. Water wash the vehicle and dry it with a clean cloth
2. Electrolyte Check level & top-up
3. Battery terminals Clean and apply petroleum jelly
4. Drive chain free play Check, clean, lubricate & adjust
5. Rear brake pedal pivot Lubricate
6. Rear brake Adjust
7. Wheel rim front & rear Check spokes tightness
8. Front brake Check & top up brake fluid level
9. Front fork oil leak..... Check for leak
10. Air filter element Clean
11. Spark plugs (2 Nos) Check, clean & adjust gap
12. H.T. Leads Inspect for cracks
13. Fuel pump..... Check
14. Fuel hose Inspect for cracks
15. Rubber hose, Air filter to throttle body..... Inspect for cracks
16. Accelerator..... Check & adjust play
17. Clutch cable Adjust play
18. Steering free play Check & Adjust
19. Engine oil Check level & top-up
20. Hand levers & kick starter pivot..... Lubricate
21. Oil filter element, oil strainer & magnetic drain plug.. Clean

CUSTOMER COPY

Job Card No:

--	--	--	--	--	--	--	--

Date :

--	--	--	--	--	--	--	--

Odo Reading :

--	--	--	--	--	--	--	--

Name of Dealer/
ASP with Code:

.....
.....

ASP / Dealer's
Stamp & Signature

3rd Free Service Activities

1. Water wash the vehicle and dry it with a clean cloth	
2. Electrolyte	Check level & top-up
3. Battery terminals	Clean and apply petroleum jelly
4. Drive chain free play	Check, clean, lubricate & adjust
5. Rear brake pedal pivot	Lubricate
6. Rear brake.....	Cam clean, lubricate & Adjust play
7. Swing Arm bush & spacer.....	Lubricate
8. Wheel rim front & rear	Check spokes tightness
9. Front brake	Check & top up brake fluid level
10. Tyres front & rear	Check wear and tread depth
11. Air filter element	Clean
12. Spark plugs (2 Nos).....	Check, clean & adjust gap
13. H.T. Leads	Inspect for cracks
14. Fuel pump/Fuel hose	Check / Inspect for cracks
15. Rubber hose, Air filter to throttle body	Inspect for cracks
16. Accelerator cable	Check & adjust play
17. Clutch cable	Adjust play
18. Engine oil sump strainer	Clean
19. Engine oil & oil filter paper element.....	Replace
20. Throttle body / Injector.....	Clean by carbo spray*
21. Hand levers & kick starter pivot.....	Lubricate
22. PAV System	Check & Clean
23. Steering System	Check, Lub. steering balls & adj. play

*Recommended - ITW Chemin or Wurth

CUSTOMER COPY

Job Card No:

Date :

Odo Reading :

Name of Dealer/
 ASP with Code:

ASP / Dealer's
 Stamp & Signature

4th Free Service

**4TH
FREE
SERVICE**

9000 Kms
or
270±15 days
whichever is
earlier from the
date of sale

Enter the Details
in Free Service
Record

(Cost of oil,
oil filter element
and other
consumables
used are
chargeable to
the customer)

9000 KMS OR 270±15 DAYS WHICHEVER IS EARLIER FROM DATE OF SALE	
Customer Name :	Dealer Code : <input type="text"/>
Address :	
Frame No: <input type="text"/>	Regn. No: <input type="text"/>
Engine No: <input type="text"/>	Sale Date: <input type="text"/>
Vehicle Installation Form No. <input type="text"/>	Serviced Date: <input type="text"/>
ODO Reading : <input type="text"/>	Serviced by (Dealer's/ASP Name & Address)
Sold by (Dealer's Name & Address)	
Received the above vehicle after the service having been done to my entire satisfaction.	
Customer's Signature :	Date : <input type="text"/>
Contact Phone / Mobile No.: <input type="text"/>	

4th Free Service Activities

1. Water wash the vehicle and dry it with a clean cloth
2. Electrolyte Check level & top-up
3. Battery terminals Clean and apply petroleum jelly
4. Drive chain free play Check, clean, lubricate & adjust
5. Rear brake pedal pivot Lubricate
6. Rear brake / cam Lubricate & Adjust
7. Wheel rim front & rear Check spokes tightness
8. Front brake Check & top up brake fluid level
9. Front fork oil leak Check for leak & replace oil
10. Air filter element Clean
11. Spark plugs (2 Nos) Check, clean & adjust gap
12. H.T. Leads Inspect for cracks
13. Fuel pump Check
14. Fuel hose Inspect for cracks
15. Rubber hose, Air filter to throttle body Inspect for cracks
16. Accelerator cable Check & adjust play
17. Clutch cable Adjust play
18. Engine oil Check & top-up
19. Hand levers & kick starter pivot Lubricate
20. Steering System Check, Lub. steering balls & adj. play
21. Tyres Check wear and tread depth

CUSTOMER COPY

Job Card No:

--	--	--	--	--	--	--	--

Date :

--	--	--	--	--	--	--	--

Odo Reading :

--	--	--	--	--	--	--	--

Name of Dealer/
ASP with Code:

.....
.....

ASP / Dealer's
Stamp & Signature

Paid Service/Maintenance Record

93

CUSTOMER COPY

12,000 ± 250 Kms. Service
Job Card No :..... Date :
Odo Reading : Dealer Code :
Brief Work Done :
Dealer's Stamp & Signature

DEALER / ASP COPY

12,000 ± 250 Kms. Service
Job Card No :..... Date :
Odo Reading : Dealer Code :
Brief Work Done :
Dealer's Stamp & Signature

CUSTOMER COPY

15,000 ± 250 Kms. Service
Job Card No :..... Date :
Odo Reading : Dealer Code :
Brief Work Done :
Dealer's Stamp & Signature

DEALER / ASP COPY

15,000 ± 250 Kms. Service
Job Card No :..... Date :
Odo Reading : Dealer Code :
Brief Work Done :
Dealer's Stamp & Signature

Paid Service/Maintenance Record

94

DEALER / ASP COPY

12,000 ± 250 Kms. Service

Brief Work Done :

Dealer's Stamp & Signature

CUSTOMER COPY

12,000 ± 250 Kms. Service

Brief Work Done :

Dealer's Stamp & Signature

DEALER / ASP COPY

15,000 ± 250 Kms. Service

Brief Work Done :

Dealer's Stamp & Signature

CUSTOMER COPY

15,000 ± 250 Kms. Service

Brief Work Done :

Dealer's Stamp & Signature

Paid Service/Maintenance Record

95

CUSTOMER COPY

18,000 ± 250 Kms. Service
Job Card No :..... Date :
Odo Reading : Dealer Code :
Brief Work Done :
Dealer's Stamp & Signature

DEALER / ASP COPY

18,000 ± 250 Kms. Service
Job Card No :..... Date :
Odo Reading : Dealer Code :
Brief Work Done :
Dealer's Stamp & Signature

CUSTOMER COPY

21,000 ± 250 Kms. Service
Job Card No :..... Date :
Odo Reading : Dealer Code :
Brief Work Done :
Dealer's Stamp & Signature

DEALER / ASP COPY

21,000 ± 250 Kms. Service
Job Card No :..... Date :
Odo Reading : Dealer Code :
Brief Work Done :
Dealer's Stamp & Signature

Paid Service/Maintenance Record

96

DEALER / ASP COPY

18,000 ± 250 Kms. Service

Brief Work Done :

Dealer's Stamp & Signature

CUSTOMER COPY

18,000 ± 250 Kms. Service

Brief Work Done :

Dealer's Stamp & Signature

DEALER / ASP COPY

21,000 ± 250 Kms. Service

Brief Work Done :

Dealer's Stamp & Signature

CUSTOMER COPY

21,000 ± 250 Kms. Service

Brief Work Done :

Dealer's Stamp & Signature

Paid Service/Maintenance Record

97

CUSTOMER COPY

24,000 ± 250 Kms. Service
Job Card No :..... Date :
Odo Reading : Dealer Code :
Brief Work Done :
Dealer's Stamp & Signature

DEALER / ASP COPY

24,000 ± 250 Kms. Service
Job Card No :..... Date :
Odo Reading : Dealer Code :
Brief Work Done :
Dealer's Stamp & Signature

CUSTOMER COPY

27,000 ± 250 Kms. Service
Job Card No :..... Date :
Odo Reading : Dealer Code :
Brief Work Done :
Dealer's Stamp & Signature

DEALER / ASP COPY

27,000 ± 250 Kms. Service
Job Card No :..... Date :
Odo Reading : Dealer Code :
Brief Work Done :
Dealer's Stamp & Signature

Paid Service/Maintenance Record

98

DEALER / ASP COPY

24,000 ± 250 Kms. Service

Brief Work Done :

Dealer's Stamp & Signature

CUSTOMER COPY

24,000 ± 250 Kms. Service

Brief Work Done :

Dealer's Stamp & Signature

DEALER / ASP COPY

27,000 ± 250 Kms. Service

Brief Work Done :

Dealer's Stamp & Signature

CUSTOMER COPY

27,000 ± 250 Kms. Service

Brief Work Done :

Dealer's Stamp & Signature

Paid Service/Maintenance Record

99

CUSTOMER COPY

30,000 ± 250 Kms. Service
Job Card No :..... Date :
Odo Reading : Dealer Code :
Brief Work Done :
Dealer's Stamp & Signature

DEALER / ASP COPY

30,000 ± 250 Kms. Service
Job Card No :..... Date :
Odo Reading : Dealer Code :
Brief Work Done :
Dealer's Stamp & Signature

CUSTOMER COPY

33,000 ± 250 Kms. Service
Job Card No :..... Date :
Odo Reading : Dealer Code :
Brief Work Done :
Dealer's Stamp & Signature

DEALER / ASP COPY

33,000 ± 250 Kms. Service
Job Card No :..... Date :
Odo Reading : Dealer Code :
Brief Work Done :
Dealer's Stamp & Signature

Paid Service/Maintenance Record

100

DEALER / ASP COPY

30,000 ± 250 Kms. Service

Brief Work Done :

Dealer's Stamp & Signature

CUSTOMER COPY

30,000 ± 250 Kms. Service

Brief Work Done :

Dealer's Stamp & Signature

DEALER / ASP COPY

33,000 ± 250 Kms. Service

Brief Work Done :

Dealer's Stamp & Signature

CUSTOMER COPY

33,000 ± 250 Kms. Service

Brief Work Done :

Dealer's Stamp & Signature

Notes

Notes

What Vehicle do you own now ?

Motor Cycle

First Time Two - Wheeler Buyer	FB 01	HERO HONDA / HERO		Yamaha SS 125	EY 13	Bajaj Pulsar 200 / 220	BA 15
ROYAL ENFIELD		HH CD 100 / CD 100 SS	HH 01	Yamaha SZX	EY 14	Ninja 250R	BA 16
Royal Enfield Bullet 350 (CI)	RE 01	HH Sleek	HH 02	Yamaha SZR	EY 15	Ninja 650R	BA 17
Royal Enfield Bullet DLX	RE 02	HH Splendor	HH 03	Yamaha FZ16	EY 16	KTM Duke	BA 18
Royal Enfield Bullet Campus	RE 03	HH Street / DLX	HH 04	Yamaha FZ5	EY 17	TVS - SUZUKI / TVS	
Royal Enfield Machismo	RE 04	HH CBZ Drum / Disc / ES	HH 05	Yamaha Fazer	EY 18	TVS - Suzuki Max 100	TS 01
Royal Enfield Machismo A350	RE 05	HH Passion	HH 06	Yamaha YZF - R15	EY 19	TVS - Suzuki Max 100 R	TS 02
Royal Enfield Lightning	RE 06	HH Ambition 125 /135	HH 07	Yamaha Enticer	EY 20	TVS - Suzuki Samurai	TS 03
Royal Enfield Lightning 535	RE 07	HH Super splendor	HH 08	Yamaha Above 500 cc	EY 21	TVS - Suzuki Shogun	TS 04
Royal Enfield Electra 4S	RE 08	HH Splendor Plus / NXG	HH 09	KINETIC		TVS - Suzuki Shaolin	TS 05
Royal Enfield Electra 5S	RE 09	HH Hunk / Extreme	HH 10	Kinetic KA 80	KE 01	TVS - Suzuki Fiero / ES	TS 06
Royal Enfield Thunderbird (LB)	RE 10	Hero Ignitor	HH 11	Kinetic K4 100	KE 02	TVS Sport	TS 07
Royal Enfield Bullet 350 UCE	RE 11	Hero Impulse	HH 12	Kinetic Challenger	KE 03	TVS Star City / DLX	TS 08
Royal Enfield Electra UCE	RE 12	Hero CD Dawn / DLX	HH 13	Kinetic GF Laser / 125 / 150	KE 04	TVS Max 4R	TS 09
RE Thunderbird Twin Spark	RE 13	Hero Splendor Pro	HH 14	Kinetic Aquila	KE 05	TVS Jive	TS 10
Royal Enfield Classis 350	RE 14	Hero Passion Pro	HH 15	Kinetic Stryker	KE 06	TVS Flame SR / DS	TS 11
Royal Enfield Classis 500	RE 15	Hero Glamour	HH 16	Kinetic Boss	KE 07	TVS Apache / RTR	TS 12
SUZUKI MOTORCYCLE		Hero Achiever	HH 17	Kinetic Velocity	KE 08	TVS Victor / GLX / GS	TS 13
Suzuki GW 250	SM 01	Hero CBZ Xtreme	HH 18	Kinetic Comet	KE 09	LML	
Suzuki Slingshot	SM 02	Hero Karizma / ZMR	HH 19	BAJAJ		LML Energy / FX	LM 01
Suzuki GS 150R	SM 03			Bajaj M80 / Major	BA 01	LML Adreno / FX	LM 02
Suzuki Heat	SM 04	ESCORT YAMAHA / YM		Bajaj KB 100 / RTZ	BA 02	LML Freedom DX / Prima / Topper	LM 03
Suzuki Zeus	SM 05	Escort Rajdoot	EY 01	Bajaj 4S Champion	BA 03	LML Graptor / Beamer	LM 04
Suzuki Above 500 cc	SM 06	Escort Ace	EY 02	Bajaj KB 125	BA 04		
HONDA MOTORCYCLE		Escort Yamaha RX 100	EY 03	Bajaj Boxer AT & CT	BA 05	MAHINDRA	
Honda Dream Yuga	HM 01	Escort Yamaha RX 135	EY 04	Bajaj Caliber / SM	BA 06	Mahindra Stallio	MA 01
Honda CB Twister	HM 02	Escort Yamaha RXZ	EY 05	Bajaj Acer 100	BA 07	Mahindra Macho	MA 02
Honda CB Shine	HM 03	Yamaha RX135(5S)	EY 06	Bajaj Pulsar 150 / 180	BA 08		
Honda CBF Stunner	HM 04	Yamaha YBX	EY 07	Bajaj Eliminator	BA 09		
Honda CB Unicorn	HM 05	Yamaha YD 125	EY 08	Bajaj Cageva CRX 3	BA 10		
Honda CB Unicorn Dazzler	HM 06	Yamaha Crux	EY 09	Bajaj Avenger	BA 11		
Honda CBR 150R	HM 07	Yamaha Libero	EY 10	Bajaj Platina 110/ 125	BA 12		
Honda CBR 250R	HM 08	Yamaha Gladiator	EY 11	Bajaj Discover 100 / 125 / 150	BA 13		
Honda Above 500 cc	HM 09	Yamaha YBR 110 / 125	EY 12	Bajaj Pulsar 135	BA 14		

Scooters

LML	SC 01	Bajaj	SC 02	Kinetic	SC 03	Piaggio	SC 04	Hero	SC 05
TVS	SC 06	Suzuki	SC 07	Honda	SC 08	Yamaha	SC 09		

Mopeds

Bajaj	MD 01	TVS	MD 02	Escorts	MD 03	Hero Puch	MD 04		
Kinetic	MD 05	Hero Majestic	MD 06	Avanti	MD 07				

Car (Below 1000 cc)	CR 01	Car (1000 to 2000 cc)	CR 02	Car (Above 2000cc)	CR 03	Others	OT 01
---------------------	-------	-----------------------	-------	--------------------	-------	--------	-------

The reason I have booked and willing to wait for a Royal Enfield is

TICK THE OPTION MOST SUITABLE	Definitely Agree	Agree	Maybe	Disagree	Definitely Disagree
Because it is my dream bike since childhood.					
There is no other 350cc bike.					
This kind of styling is not available on any other bike.					
Because this is a Royal Enfield am willing to wait.					
Other Reasons.					

I would rate my experience in this counter as-

TICK THE OPTION MOST SUITABLE	Excellent	Good	Could be better	Not good	Extremely Bad
Attitude and Capability of people.					
Test ride.					
Communication during waiting period.					
Ease of booking and other formalities.					
Bike delivery and information given.					

Customer's Signature & Date

Dealer's Signature & Rubber Stamp Seal

Format No. F/14A/CS/03, Sep 2012 DLR/CS Copy



PRE DELIVERY INSPECTION LIST

MODEL: BULLET 350 / ELECTRA / CLASSIC 350 / CLASSIC 500 / BULLET 500

Model :		Engine No:							
Dealer's Name :		Location:							
Colour :		Key Number :							
Battery Number :		Battery Make :		Tyre Number :		Front :		Rear :	
Aggregate	Area	Defect Code	Measure	Defect #1	Defect #2	Defect #3	Remarks		
CHASSIS / ENGINE NUMBER	1 Engine / Vehicle Number Details	DF	Same						
CONNECT BATTERY / CHECK VOLTAGE	2 Battery Charging	D / NC / Weak Cell	Battery Voltage 12V-whereas 13.5 V (Max. online voltage)						
ENGINE OIL	3 Replace oil & oil filter / Check Oil level (3 Drain Bolts system Hex 19mm, 8mm X 2nos and Hex 12mm head bolts)	EO - (Drained Oil Level)	Fill 2.5 Litres (Capacity is 2.75 Litres) - Remove 3 Drain Bolts to Drain the complete Oil						
	4 Clean Primary Oil Strainer screen	-	Clean						
LOCK OPERATION	5 Ignition / Side Air Filter Box / Tool Box Lock / Fuel Tank Lock	H / LF / NW	Same						
PETROL	6 Fill Petrol	-	5 Litres						
FRONT WHEEL	7 Brake Lever Free Play	EP / T	2-3 mm / (STD)						
	8 Caliper Mounting Bolts	LF	2.7 to 3.0 Kgm						
	9 Front Wheel Rotation	W / T / LF / N	Free (Check Spokes Looseness & Runout)						
	10 Front Mudguard Alignment / Cover Tube Rubbing	M / RB	Straight						
	11 Front Wheel Nut	LF	7.0 to 7.7 Kgm						
	12 Front Tyre Condition (Check Tyre Line Seating)	WF	Good						
CLUTCH	13 Front Tyre Pressure	LESS	22 PSI						
	14 Clutch Operation	H / N	Smooth						
HANDLE BAR CONTROLS & ELECTRICAL SWITCH OPERATIONS	15 Clutch Lever Free Play	EP / V / T	2 - 3 mm						
	16 Accelerator Operation	T / SY	Smooth						
	17 Lever Brackets Tightness	LF	Tight						
	18 Switch Modules Tightness	LF	Tight						
	19 Steering Movement	T	Free						
	20 Handle Bar Positioning	WF	W.r.to Dot Punch						
	21 Lock Nut T- Stem	LF	4.5 to 5.5 Kgm						
FUEL SYSTEM	22 Electrical Switch Operation	NW / F	No Defects						
	23 Neutral Lamp	NW / F	No Defects						
	24 Fuel Tap Operation	H / NW	Smooth / Main / Reserve						
REAR WHEEL	25 Fuel Leak	L	No Leak (Tank, Tap, Carburetor)						
	26 Fuel Tank Alignment	M	Straight						
	27 Rear Brake Pedal Free Play	T / EP	20 - 30 mm						
	28 Pedal Position w.r.t foot rest	DF	Same Level						
	29 Chain Tension	T / EP	20 - 25 mm						
	30 Rear Wheel Rotation	W / T / LF / N	Free (Check Spokes Looseness & Runout)						
	31 Anchor Pin Nut	LF	4.5 Kgm						
	32 Rear Mudguard Alignment	M	Straight						
	33 Rear Tyre Pressure	LESS	32 PSI						
	34 Rear Tyre Condition (Check Tyre Line Seating)	WF	Good						
	35 RR Shock Absorber Operation / Adjustment	H / N / AD	Smooth						

AESTHETICS	36	Mudguards - Paint / Plating Related	SC / PD / R / DN	No Defects (Mudguards / Fuel Tank / Tool Box)						
	37	Fuel Tank - Paint Related	SC / PD / R / DN	No Defects						
	38	Tool Box LH, Air Filter Box, Battery Cover - Paint / Plating Related	SC / PD / R / DN	No Defects						
	39	Head Lamp Casing - Paint Related	SC / PD / R /	No Defects						
	40	Powder Coated Parts (Scratch / Rust / Chipped OFF)	SC / PD / R	No Defects						
	41	Plated Parts (Scratch / Rusty)	SC / R / PO	No Defects (Mudguards / Fuel Tank / Wheel Rim / Indicator)						
	42	Buffed components poor Buffing & Scratches	SC / DU	No Defects						
	43	Seat Alignment	M	No Defects						
	44	Indicators Alignment (MFR / Amber)	M	No Defect / Colour				Lens Colour Check		
	45	Stickers / Knee Pads	M / LF / SC	No Defects						
OTHERS	46	Nuts, Bolts, Fasteners (Torque)	LF	Tight (RH, LH Cover / Engine Foundation / Accessories / Wheel Nut)						
	47	Owner's Manual & Tool Kit Content	-	Availability						
	48	Spare Fuse in Fuse Carrier	NA	Tubular / Blade Fuse						
TEST RIDE	49	Starting (Kick Start / Self Start)	ST / N	Easy Start						
	50	Front / Rear Brakes Effectiveness / Feel	AD / SG	Sharp						
	51	Pulling	P	Straight						
	52	Vibration	V	Smooth						
	53	Wobbling	W	No Defects						
	54	Front Fork / Drive Chain Noise	N	No Defects						
	55	Engine Performance / Gear Shifting / TPS Setting	N / ST / J / H	Smooth						
STATIC CHECK (AFTER TEST RIDE)	56	Any Rattling / Squeaking Noise	N	Nil (Silencer / Accessories / Body Parts / Suspension)						
	57	Easy Start (Hot Condition)	ST / NW	Smooth						
	58	Leak	L	No Leak (Oil / Fuel / Hydraulic / Acid Leakage)						
	59	Smoke / Oil Droplets in Silencer	SK / EO	No Smoke						
60	Cam Noise / Top End Noise	N	Smooth							
ANY OTHER										
Note **	Any Abnormal Noise or Engine Open cases during PDI Inform to Plant / Factory									

INSTRUCTIONS

- | | |
|---|--|
| <ol style="list-style-type: none"> 1. Check the vehicle thoroughly for any transit damages or shortage of parts. 2. Carry out all jobs listed under Pre-delivery Inspection Schedule. 3. Thoroughly road - test the vehicle for performance. | <ol style="list-style-type: none"> 4. Please ensure delivery of the vehicle in brand new condition. 5. Claim transit loss and damage through 'TRANSIT' insurance only. 6. Claim Parts replaced for Manufacturing defects only under warranty. |
|---|--|

Misalignment	Noise	Vibration	Leak	Starting Trouble/Missing	Less	Wobbling	Loose Fitment	Discharging	Tight	Fused	Scratch	Pulling	Dent	Wrong Fitment	Hard	Jerking
M	N	V	L	ST	LESS	W	LF	D	T	F	SC	P	DN	WF	H	J

Excess Play	Different	Spongy	Sticky	Not Available	Smoke	Adjustment	Not Working	Paint Defect	Rust	Peel Off	Dull	Excessive Oil	Rubbing	Not Charging
EP	DF	SG	SY	NA	SK	AD	NW	PD	R	PO	DU	EO	RB	NC

ROYAL ENFIELD**BIKE INSTALLATION CONFIRMATION BY CUSTOMER**

We congratulate you on becoming a proud owner of Royal Enfield bike. We request you to give this feedback after completion of the delivery process.

		YES	NO
1	Bike Documents explained (Invoice, Insurance, RC / Road Tax Receipt)		
2	Owner's Manual received		
3	Recommended Lubricants explained		
4	Maintenance Schedule sheet in Owner's Manual shown and explained		
5	Next Free Service due explained		
6	All Free / Paid Services explained		
7	Warranty Guidelines explained		
8	"Running in period" details shown in the manual explained		
9	Service Station Address given and Location explained		
10	Service Incharge Name & Mobile No given		
11	Bike delivered in neat and clean condition		
12	Tool Kit & First Aid Kit received and explained		

		YES	NO
13	Control Switches & Disc Brake System usage explained		
14	Fuse Box location shown and explained		
15	Recommended Tyre Pressure explained		
16	Bike starting & Gear shifting procedure explained		
17	Quantity of Fuel in Fuel Tank informed		
18	Bike orientation & short distance drive provided		
19	Date and Time of Installation		
20	Name of Person who did Installation		
Suggestions If Any:			
			CUSTOMER SIGNATURE
Model:		Registration No.:	
Chassis No.:			
<i>We thank you and request you to return this filled up form to the person who did the bike installation for you</i>			
<i>KEEP RIDING</i>			

FORM 22

[See Rules 47(g), 115, 124 (2), 126A and 127 (1), 127 (2)]

**INITIAL CERTIFICATE OF COMPLIANCE WITH POLLUTION STANDARDS, SAFETY
STANDARDS OF COMPONENTS AND ROAD WORTHINESS**

Certified that the following vehicle complies with the provisions of the Motor Vehicles Act, 1988, and the rules made there under, including the following mass emission norms:

Brand name of the vehicle	:-	Classic 500
Chassis number	:-	
Engine number/motor number (in case of battery operated vehicles)	:-	
Sub-rule No. of rule	:-	115(2)(i), 115(14)(F)
Emission norms [Bharat Stage-I/II/III/Bharat (Trem) Stage-III etc.]	:-	Bharat Stage III

Date :

For **ROYAL ENFIELD**

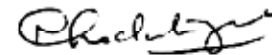

Quality Assurance



ROYAL ENFIELD

ROYALENFIELD.COM